

Installation Instructions for Combination Service & Spring Brake:



INSTALLATION STEPS

1 Ensure Spring Brake Is Caged

Prior to spring brake installation, ensure the spring brake is caged. If the spring brake is NOT caged, see instructions on "MECHANICAL RELEASE OF SPRING BRAKE (CAGING) ALL TYPES" in the Chamber Customization Guide.

Note: Failure in not caging the spring brake for installation may cause main spring to not fully engage the foundation brake components, which could cause insufficient braking force.

Always block wheels on brake actuators to prevent rollaway.

2 Inspect Mounting Bracket:

Inspect the brake mounting bracket on the axle. The bracket must be free from excessive paint (less than .010" (.25mm) thick), debris, burrs, and cracks. The bracket must also be flat to .02" (0.5mm). See Figure 1

3 Mount Brake Chamber To Bracket:

Always mount the brake chamber directly to the bracket. DO NOT add or insert shims, spacers, washers, or reinforcing plates between the brake service base and the bracket. See Figure 2.

Figure 1

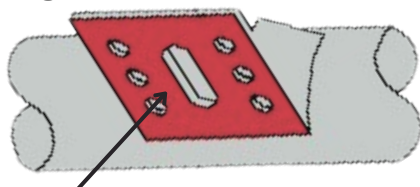

BE CERTAIN THAT THE MOUNTING BRACKET SURFACE IS FREE OF DEBRIS, BURRS, CRACKS AND IS FLAT WITHIN .02 INCHES (0.5mm)

Figure 2

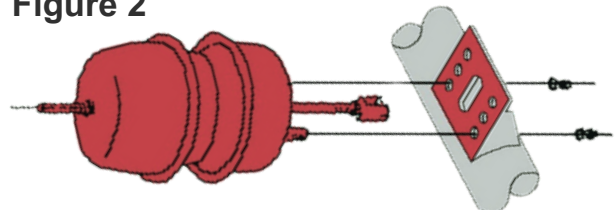

ALWAYS MOUNT THE BRAKE CHAMBER DIRECTLY TO THE BRACKET

4

Determine Push Rod

If your brake doesn't have a correct precut Push rod, see instructions on "DETERMINE CORRECT PUSH ROD LENGTH" in the Chamber Customization Guide.

5

Install Clevis & Jam Nut

Install the clevis and jam nut onto the service push rod if not already installed. The service push rod should protrude no more than two threads into the clevis throat or no less than one thread into the clevis body. Torque the jam nut to 45-50 ft-lbs (61-68 Nm).

NOTE: There may be multiple mounting holes on the brake mounting bracket. Consult your axle manufacture for the correct location. Failure to do so may result in premature diaphragm wear or service push rod buckling.

6

Align Slack Adjuster:

Before installing the spring brake, move the slack adjuster arm in the opposite direction to the brake mounting bracket by turning the hex nut (use a hand wrench) until there is enough space for the push rod to fit in.

7

Install Mounting Nuts

Install the mounting nuts and washers. Torque nuts to 133-155 ft-lbs (180-210 Nm).

8

Remove Cotter Pin

Remove cotter pin from clevis pin. Do not discard. These parts are reused.

9

Readjust Slack Adjuster

Readjust the slack adjuster arm and move it toward the spring brake by turning the adjusting hex nut. Check to make sure the brake pads are not in contact with the drum. Align the slack adjuster arm with the center of the push rod clevis.

NOTE: Consult your axle or vehicle manufacture for the correct slack adjuster length and correct slack adjuster hole location on the slack adjuster. Failure to do so may result in premature diaphragm wear or service push rod buckling.

10

Install Clevis & Cotter Pin

Align slack adjuster arm with the center of the push rod clevis. Install clevis pin and cotter pin.

11

Inspect Angle

Check to be sure the angle formed by the slack adjuster and the brake chamber push rod is greater than 90° (when the brake is in the caged position). See figure 3.

12

Shim Slack Adjuster

Install the slack adjuster retaining mechanism on the end of the "Scam" spline shaft, being sure to shim inboard or outboard if necessary for the slack adjuster to maintain $\pm 2^\circ$ lateral alignment with the push rod. Shim the slack adjuster to maintain less than .060" (1.52mm) lateral end play or consult your axle manufacture for the correct lateral end play requirement.

Figure 3

PUSH ROD ANGLE
GREATER THAN 90°

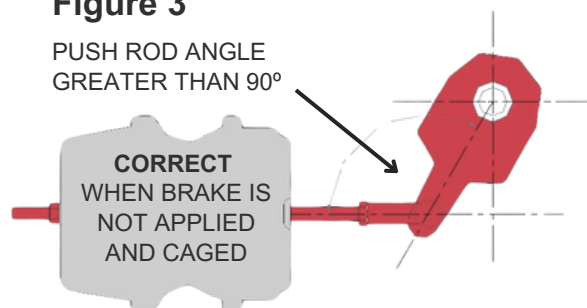

SPECIAL NOTE : For additional information, consult the slack adjuster manufacturer, or TMC Recommended Practice, RP 609A, VMRS 013001, 013002 for automatic and manual slack adjuster installations.

13

Remove Cotter Pin

Connect the service and emergency air lines to the proper air ports, torque the service and emergency air lines to 26-33 ft-lbs (35-45 Nm). It is recommended that a commercial grade thread sealing compound be used on air line adapters before installation into the air ports. Deform the cotter pin on the clevis assembly and uncage the brake. (Uncage the brake by adding air pressure to the parking side and turning the release bolt nut counterclockwise with finger or a hand wrench; do not use an impact wrench. Turn the release bolt counterclockwise 1/2 turn and pull it out.)

14

Vehicle or Shop Air Pressure

Apply vehicle or shop air pressure, 120 psi (8.3 bar) or 90 psi (6.2 bar) minimum, to the emergency side of the brake three times. Maintain vehicle or shop air pressure. Check for leaks.

15

Measure Twice Cut Once

Check the brake chamber for vertical alignment. The brake is adjusted correctly if the service push rod is as shown in Figure 4.

If setup results in the condition shown in Figure 5 or 6, the brake chamber is misaligned and must be corrected. Failure to do so will result in premature diaphragm wear or bent push rod.

Check that the clevis pin is connected to the correct hole in the slack adjuster arm (if more than one is present). Reconnect as needed. Also check that the slack adjuster arm length is correct for the application according to the vehicle or axle manufacturer's instructions.

Check that the spring brake is installed in the correct holes in the axle bracket. The mounting hole position is determined by the length of the slack adjuster arm. Re-install as needed.

If the set up results as shown in Figure 5:

The pushrod may be too long. Check that the pushrod length is correct according to the slack adjuster manufacturer's instruction. Shorten as needed.

Always measure twice and cut once.

If the set-up results as shown in Figure 6:

The pushrod may be too short. Check that the pushrod length is correct according to the slack adjuster manufacturer's instruction. If is too short then a new spring brake will need to be installed.

Install the release tool in the tool pocket and tighten the washer and nut to 5-11 ft-lbs (7-15 Nm). Install the dust plug into the release tool access hole in the center of the spring housing.

Figure 4

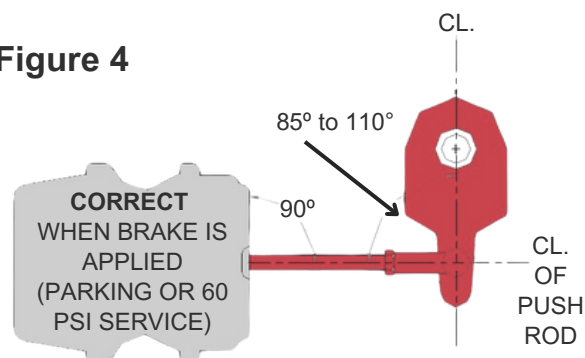

Figure 5

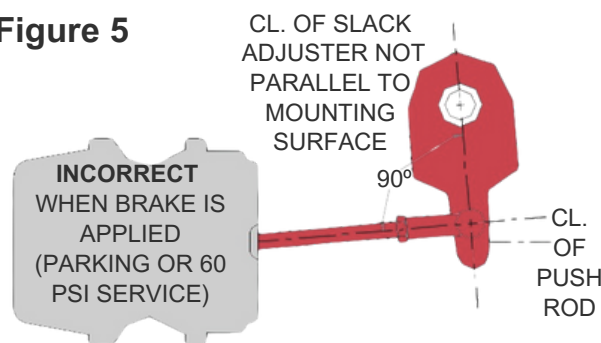

Figure 6

