

# TFO wheel end maintenance

A complete guide to trouble-free operation of heavy duty bearings, seals, hubcaps, lubricants and more



# A systems approach to total wheel end maintenance



SKF's Trouble-Free Operation (TFO) Program is a proven systems approach to heavy duty maintenance. By providing fleets with detailed instructional materials, and making hands-on training available to your technicians, this program has made a significant contribution to many fleets' overall productivity.

This wheel end maintenance guide, central to the TFO program, is based on our core experience with bearings and seals over several decades and literally billions of over-the-road truck miles.

After years of investigating premature seal leaks and/or bearing failures, we've learned that improper removal and installation are by far the leading causes of these premature failures. Armed with the right information and tools, and using the step-by-step procedures in this manual, you can extend the service life of bearings and seals, protect your trucks from costly damage, and make your fleet safer in the process.



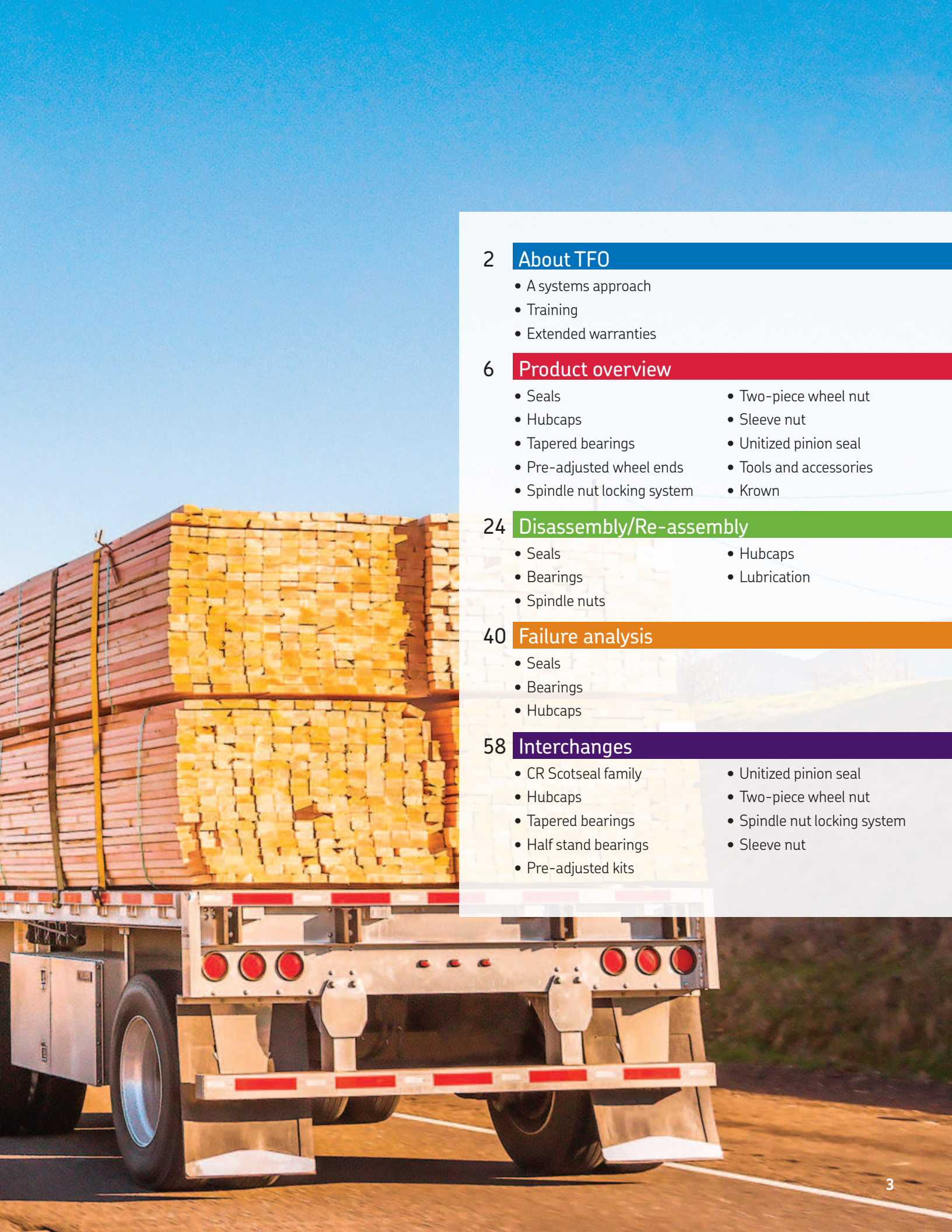

## 2 About TFO

- A systems approach
- Training
- Extended warranties

## 6 Product overview

- Seals
- Hubcaps
- Tapered bearings
- Pre-adjusted wheel ends
- Spindle nut locking system
- Two-piece wheel nut
- Sleeve nut
- Unitized pinion seal
- Tools and accessories
- Crown

## 24 Disassembly/Re-assembly

- Seals
- Bearings
- Spindle nuts
- Hubcaps
- Lubrication

## 40 Failure analysis

- Seals
- Bearings
- Hubcaps

## 58 Interchanges

- CR Scotseal family
- Hubcaps
- Tapered bearings
- Half stand bearings
- Pre-adjusted kits
- Unitized pinion seal
- Two-piece wheel nut
- Spindle nut locking system
- Sleeve nut

# SKF TFO training overview



## Providing access to SKF knowledge

SKF's Trouble-Free Operation (TFO) Program offers a proven systems approach to heavy duty maintenance. By providing detailed instructional materials and hands-on training to fleets and distributors alike, the TFO program has helped improve the overall productivity of both.

The TFO program recognizes that there are many ways to develop skills, learn about new products and procedures, and determine best practices for safe, efficient maintenance. While eLearning and technical manuals are important, nothing complements them better than a face-to-face training session with a technical expert.

With the TFO program, SKF provides such on-site technical training for counterpeople as well as technicians and installers. These hands-on training sessions offer an invaluable resource for learning about SKF heavy duty products and services.

To request an on-site training session, contact your local SKF sales representative.



## Counterperson training

- Specifically designed for sales and counter personnel
- Provides insights to help address customer needs and challenges
- Outlines SKF apps and Internet resources available to find part numbers and applications fast
- Includes a Sales Pro certificate for session participants



## TFO Clinics for technicians/installers

- Specifically designed for wheel end maintenance personnel
- Offers hands-on training for wheel end inspection, removal, installation, and bearing adjustment
- Outlines SKF apps and Internet resources available to find part numbers and applications fast
- Includes a training certificate for session participants

# Warranties under the TFO program

In addition to helping your fleet reduce wheel end maintenance and its associated costs, you can also benefit from special extended warranties on selected products when certain requirements are met. The following Aftermarket warranties are provided for the SKF line of CR Scotseals purchased under the TFO program.

	CR Scotseal X-Treme	CR Scotseal PlusXL	CR Scotseal Hybrid	CR Scotseal Classic
Tractor	5 years 500,000 miles	3 years or 300,000 miles	N/A	1 year or 100,000 miles
Trailer	5 years Unlimited	3 years Unlimited	3 years Unlimited	1 year Unlimited
Severe Service	3 years 300,000 miles	1 year or 150,000 miles	1 year or 150,000 miles	1 year or 50,000 miles

**The following conditions are required for Aftermarket warranty coverage under the TFO program:**

- SKF hubcaps must be used
- Coverage applies to genuine CR Scotseals and hubcaps only
- User must follow current TMC maintenance procedures
- SKF representative to conduct training at each fleet maintenance facility
- Wheel end maintenance records are to be monitored by SKF and fleet

**NOTE:** For further details on the warranty program, including extended OE warranties, contact your local SKF representative.

## Caution: Beware of counterfeit seals

Unscrupulous manufacturers are flooding the global market with poorly engineered and cheaply manufactured seals that have deliberately been made to resemble premium quality CR Scotseals. Most obvious is the use of green paint (not Bore Tite) that can flake off and enter the hub, actually causing bearing damage. The warranties detailed above apply only to genuine SKF brand CR Scotseals.

### A few words of caution:

- A seal's running surfaces are critical to performance. Historically, the running surfaces of counterfeit seals have been demonstrated to be well below SAE standards.
- Testing has shown these counterfeit seals to be of substantially inferior quality and highly questionable reliability.
- Premature seal failure can lead to unexpected wheel end failures that can cause vehicle downtime and damage, serious personal injury and even fatalities.

# CR Scotseal wheel seals – the right sealing solution for every application

The CR Scotseal family of seals features four product variations that are suited to your particular preference, application and environment. The entire CR Scotseal family offers you the right sealing solution for every kind of wheel end maintenance. The brand recognition, along with the outstanding quality and value, insures that you are installing the optimum seal for your operation.

The CR Scotseal Classic has become the trucking industry standard and best value for more than 30 years.

The CR Scotseal Hybrid is designed specifically for trailer applications and offers high temperature capability and is compatible with synthetic lubricants.

The CR Scotseal PlusXL provides you with an extended life seal with superior tolerance to higher wheel end temperature, and is compatible with synthetic lubricants.

The CR Scotseal X-Treme is the latest addition and offers superior performance and excellent high temperature capability and reduced friction for improved fuel economy.

Seal	# Sealing lips	Material O.D.	Install tool required	Performance		Warranty	
				Years	Miles	Tractor	Trailer
X-Treme	4	HNBRX	No	5	500k	5 yr / 500k	5 yr / unlimited
PlusXL	4	HNBR	No	3 - 5	300k	3 yr / 300k	3 yr / unlimited
Hybrid	4	HNBR	Yes	3 - 5	300k	—	3 yr / unlimited
Classic	3	Metal	Yes	1 - 3	100k	1 yr / 100k	1 yr / unlimited

See the complete CR Scotseal interchange chart on page 58



## CR Scotseal X-Treme

The CR Scotseal X-Treme seal offers exceptional performance in virtually all operating conditions. It's a unitized, one-piece hand installable seal that has three metal unitizer rings for damage free installation. This seal uses an advanced HNBRX material that provides low friction, excellent high heat capability, outstanding wear resistance, and broad compatibility with synthetic lubricants. Its low friction and high rolling efficiency provides improved fuel economy and lower emissions. Ideal for fleets looking for maximum uptime, lowest cost per mile and the best ROI seal.

### Hand installable

- Eliminates installation problems and avoids costly "do overs"
- Ends searching for the specific tool for each seal part number

### Advanced sealing materials

- HNBRX material provides outstanding performance and extreme heat resistance
- EPDM material on the ID makes a perfect seal even on worn spindles
- Provides longer life in contaminated conditions
- Compatible with all popular synthetic lubricants

### Unitized design with 4 sealing lips

- Provides clean running surfaces for sealing lips
- 3 metal unitizer rings for sealing lip protection during installation and service
- Primary Waveseal sealing lip sweeps oil back on the bearings for cooler operation
- 3 dirt barriers keep out contaminants extending service life

### Extended warranty coverage

- 5 years / 500,000 mile warranty

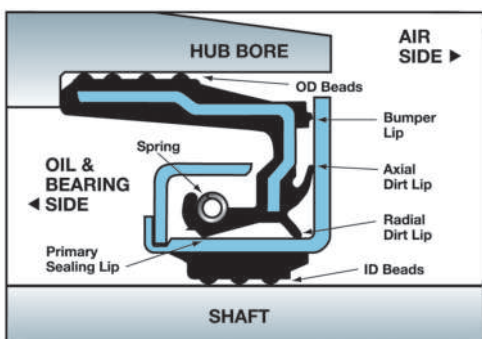

## CR Scotseal PlusXL

The CR Scotseal PlusXL is a unitized, one-piece hand installable design seal that offers maximum sealing life under virtually all operating conditions. This seal uses an advanced HNBR material that provides high temperature capability, great wear resistance, and broad compatibility with synthetic lubricants. The CR Scotseal PlusXL is the preferred choice among many OE truck and trailer manufacturers and is the OE standard seal in pre-assembled hubs, due to its proven history of high performance.

### Hand installable

- Eliminates installation problems and avoids costly "do overs"
- Ends searching for the specific tool for each seal part number

### Advanced sealing materials

- HNBR material provides great heat resistance in normal operating temperatures
- EPDM material on the ID makes a perfect seal even on worn spindles
- Provides longer life in contaminated conditions
- Compatible with all popular synthetic lubricants

### Unitized design with 4 sealing lips

- Provides clean running surfaces for sealing lips
- Primary Waveseal sealing lip sweeps oil back on the bearings for cooler operation
- 3 dirt barriers keep out contaminants extending service life

### Extended warranty coverage

- 3 years / 300,000 mile warranty

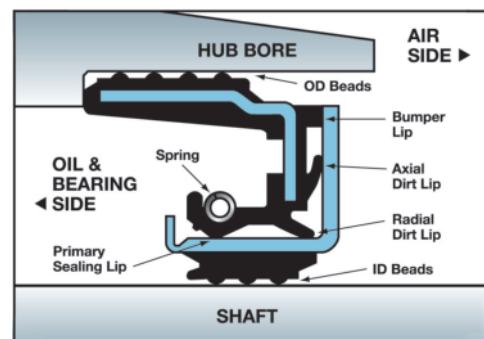

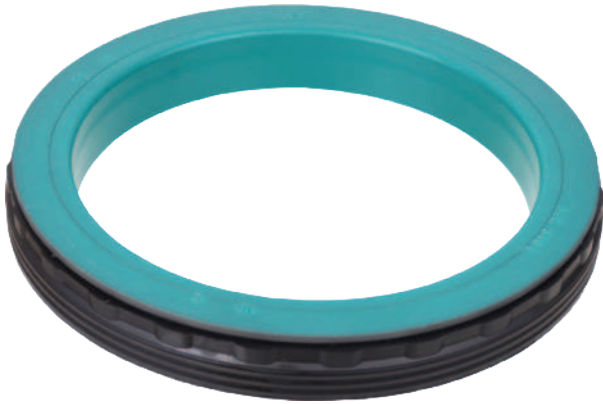

## CR Scotseal Hybrid

The CR Scotseal Hybrid is a semi unitized seal designed specifically for trailer applications that offers maximum sealing life with a low cost per mile of operation. This seal uses an advanced HNBR rubber material on the OD that provides high temperature capability, great wear resistance, broad compatibility with synthetic lubricants, and a Bore Tite coated metal ID that provides excellent static sealing and heat dissipation. The CR Scotseal Hybrid installs directly on the spindle instead of on the hub, providing easy installation, a positive seal, and easy removal.

### Spindle Mounted

- Easy installation and removal

### Rubber OD / Metal ID

- HNBR material provides great heat resistance in normal operating temperatures
- Bore Tite coated metal ID makes a perfect seal even on worn spindles
- Metal ID provides excellent heat dissipation extending seal life
- Compatible with all popular synthetic lubricants

### Semi unitized design with 4 sealing lips

- Provides clean running surfaces for sealing lips
- Primary Waveseal sealing lip sweeps oil back on the bearings for cooler operation
- 3 dirt barriers keep out contaminants extending service life

### Extended warranty coverage

- 3 years / unlimited mile warranty

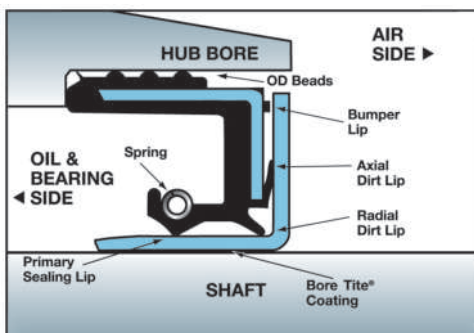

## CR Scotseal Classic

The CR Scotseal Classic is a unitized, one piece design that offers robust sealing life in a broad range of operating conditions. This seal uses a sealing element that is assembled between a metal outer and inner case. To extend service life, the three-lip sealing element contains a pre-lubed, spring-loaded primary sealing lip, a dirt exclusion lip, and an outer bumper lip. A Bore Tite coating ensures a tight and leak proof seal by filling in any small housing bore imperfections.

### Unitized design with 3 sealing lips

- Provides clean running surfaces for sealing lips
- 3 dirt lip barriers prevent oil leaks and keep out contaminants, extending service life
- Sealing element remains stationary with the spindle

### Coated with Bore Tite

- Acrylic polymer sealant helps fill in small imperfections in the bore providing a positive seal

### Reliable and dependable

- Premium quality components provide long service life
- Compatible with all popular synthetic lubricants

### Warranty coverage

- 1 year / 100,000 mile warranty

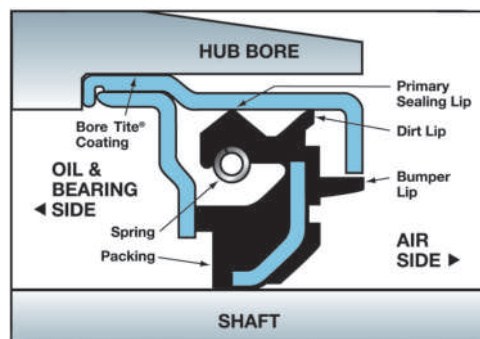

# CR Scotseal hubcap family



## Hubcaps for P.S.I. applications

- Hubcaps compatible with Meritor® Tire Inflation System (MTIS™) by P.S.I.
- Fusion-bonded window
- Oil bath and grease-packed designs
- Available in black or gray



## Hubcaps for oil bath applications

- Lightweight DuPont™ Zytel® material
- Embedded solid aluminum ring, distributes an even, leak proof load against the hub
- Increased impact resistant
- Leak-proof window is fusion-bonded to body
- Compatible with all popular oils including the latest synthetics



## Hubcaps for grease packed applications

- Designed for semi-fluid grease applications
- “Umbrella” valve vent seals out contaminations yet vents internal pressure as low as 2 psi when covered by 1/4” of grease
- Addition of a splash plate to the hubcap design helps protect against the harsh conditions created by road spray, power washers and flooded docks

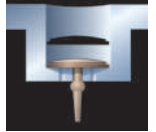

## Lexan® hubcaps

- Lightweight, molded design using GE's Lexan handles harsh conditions
- Sealed models for grease-packed systems
- Oil and grease pro-par applications



## Stamped Steel hubcaps

- Zinc-plated
- Protected with weather-resistant armor
- Resists rust and rough wear

Zytel is a DuPont material.

Lexan is a registered trademark of General Electric Company.

The CR Scotseal Trouble-Free (TF) hubcap is stronger than aluminum. Manufactured from DuPont™ Zytel®, Scotseal TF hubcaps have been proven to withstand tough over-the-road conditions, resisting chemicals, road salt, rocks and bumps. The DuPont™ Zytel® construction makes the TF hubcap 1-1/2 pounds per axle lighter.

Additionally, the Tamper-proof (TP) CR Scotseal hubcap is specifically designed for use with today's synthetic grease packed systems. The vented hubcap design forms a full 360 seal against the hubcap surface to protect wheel ends from damaging road spray, power washers and flooded docks.

- Heavy duty durability
- Oil bath and grease-packed designs
- Compatible with all popular oils and greases including the latest synthetics
- Approved by all major OE truck and trailer manufacturers with a growing number installing them as standard equipment
- Exclusion technology with multiple barriers protects seals and bearings from outside contamination.

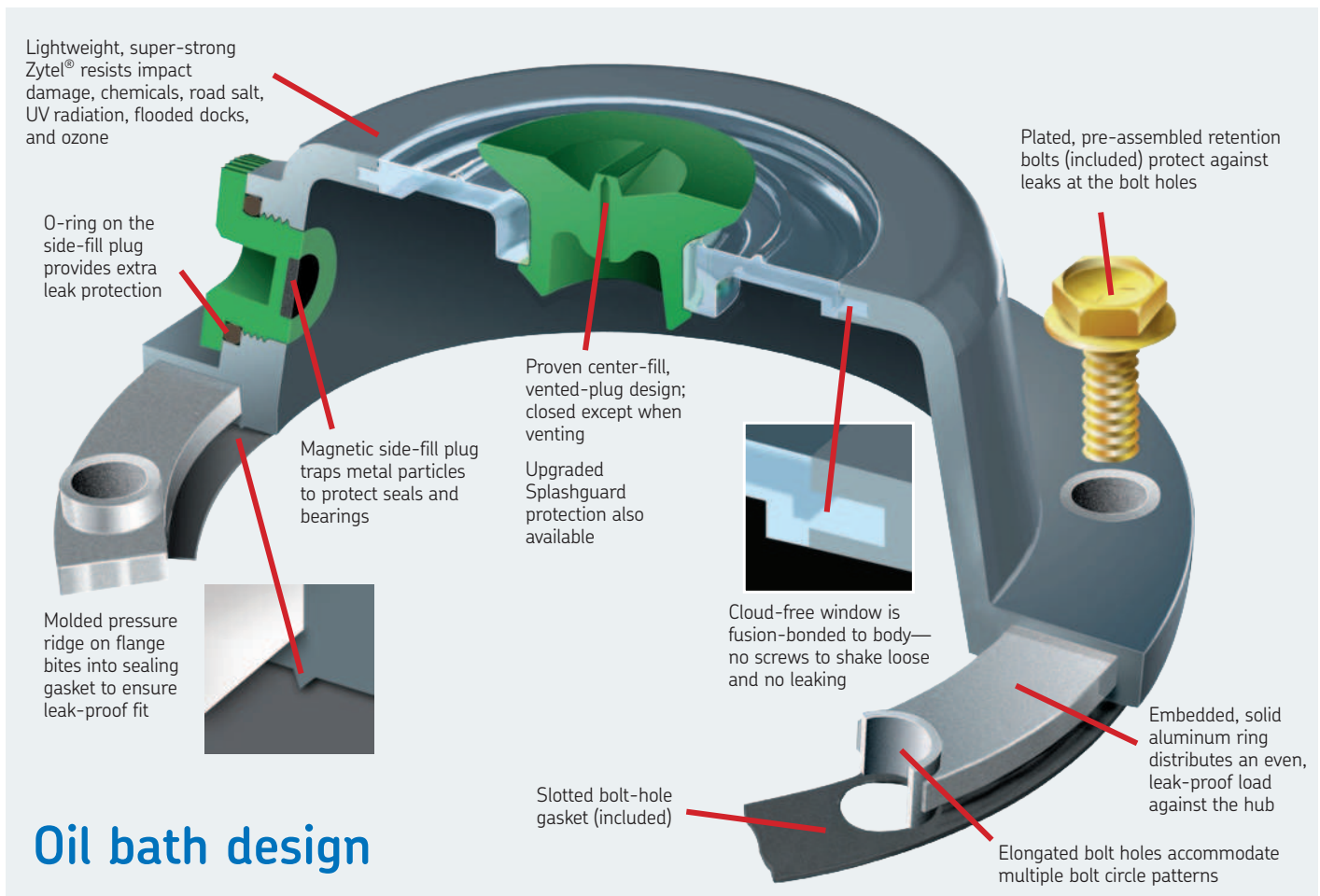

See the complete CR Scotseal TF hubcap part listing and interchange chart on page 59

# Splashguard

## Upgraded vent system and protection

SKF Splashguard technology is a contaminant exclusion system that provides extra splash protection. The Splashguard protects the wheel end from water ingestion caused by high pressure washer spray and submersion.

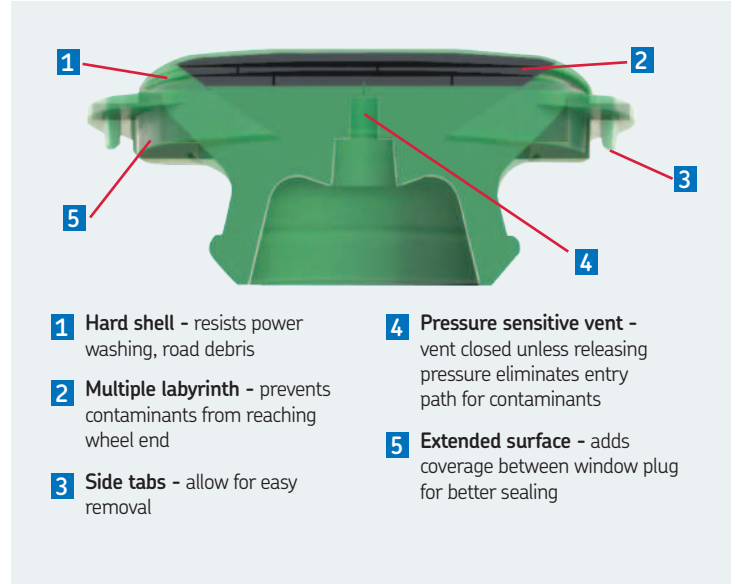

# Hubcap barrel program



SKF's most popular hubcaps in barrel quantities. Each barrel contains 75 or 100 bulk packed hubcaps with gaskets and fastening bolts. Hubcaps are packaged individually in heavy duty plastic.

Available in single box, case quantities and barrel quantities

Base part number	Add suffix for bulk qty of -24	Add suffix for barrel quantity	Barrel quantity
1343	-C24	B-100	100
1399		B-75	75
1612	-C24	B-100	100
1643	-C24	B-100	100
1644	-C24	B-100	100
1696		B-75	75
1743		B-100	100

# Tapered bearing sets

SKF tapered bearings are engineered and manufactured to the highest quality standards. Their design and superior materials provide a significant increase in operational reliability under heavy loads and misaligned conditions.

Made from the highest quality steel and engineered for longer service intervals, the construction of the tapered bearings handle a combination of radial and thrust loads. Each tapered bearing set contains a precision matched cup and cone that are specifically designed to maximize bearing performance and life. Additionally, the SKF part numbers follow industry-established numbers, allowing for easy look-up and identification for specific applications.



### Tapered bearing sets:

- Help the installer do the job right
- Ensure longer bearing life
- Help prevent premature failure
- Increase truck and trailer uptime
- Available for all popular applications

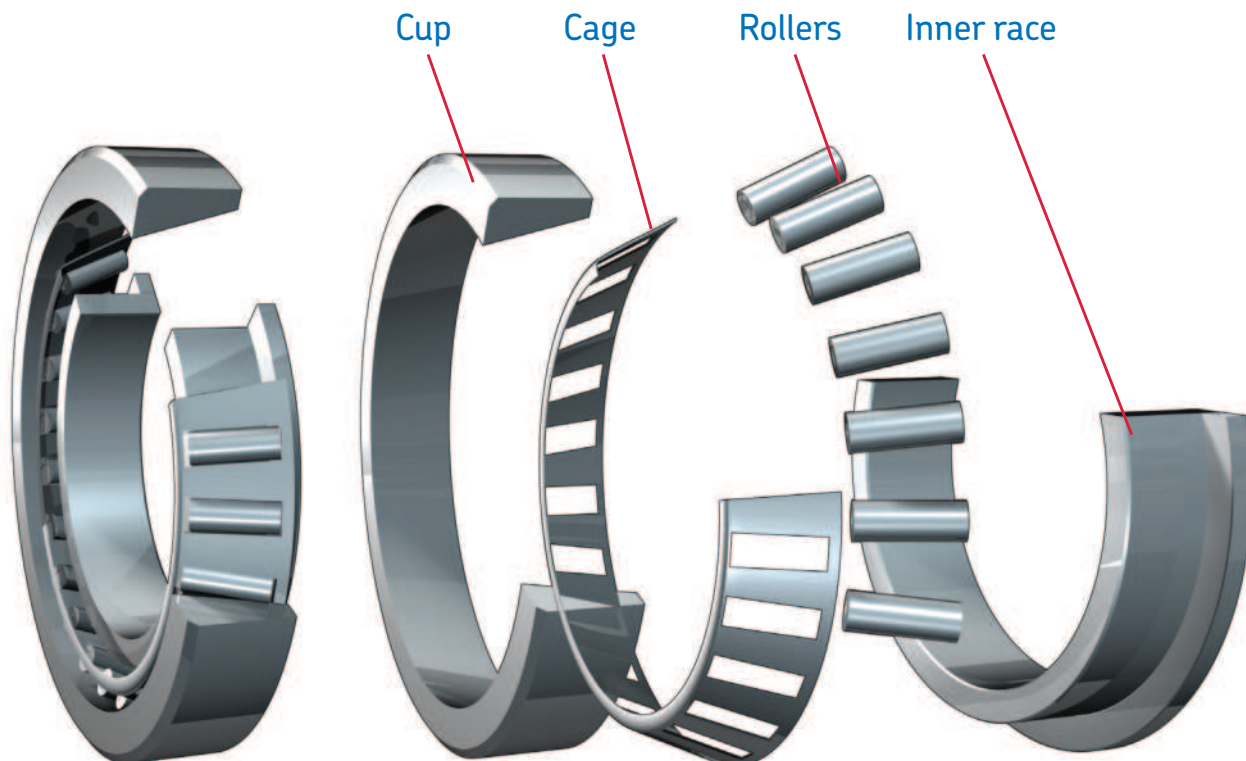

## Half stand tapered bearing sets for pre-adjusted hub assemblies

SKF also provides specifically-toleranced half stand tapered bearing sets for the pre-adjusted hub assemblies:

- World-class quality of SKF, a global OE supplier
- Precision manufactured to tighter dimensional tolerances specified by ConMet®
- Superior design and materials reduce friction and provide excellent reliability under heavy loads and misaligned conditions
- Approved as an OE tapered bearing set in pre-adjusted hub assemblies beginning in 2007



See the complete SKF tapered bearing sets part listing and interchange chart on page 60



# Rebuild kits for pre-adjusted hubs

## Pre-adjusted hub reliability and SKF quality in one convenient box

SKF addressed a big void in the commercial vehicle market by being the first to introduce an all inclusive rebuild kit for pre-adjusted hub assemblies. SKF's rebuild kit contains everything needed for successfully maintaining the wheel end and returning the truck/trailer to service. It includes the CR Scotseal PlusXL, one of the most advanced wheel seals in the industry. It also includes tighter toleranced bearing sets, a TF hubcap (if applicable), and a precision machined pre-adjusted bearing spacer.

With parts that meet the exact specifications of the original pre-adjusted system components, the rebuild kit helps ensure longer service life and less downtime. Plus, a simplified installation procedure saves time.



CR Scotseal PlusXL



Half stand tapered bearing sets (2)



TF hubcap (when applicable)



### Featuring precision machined pre-adjusted spacer

- Proprietary machined bearing spacer along with the SKF specifically toleranced bearings provides the most reliable bearing end-play setting, optimizing wheel end life
- Eliminates need for manual end-play adjustment

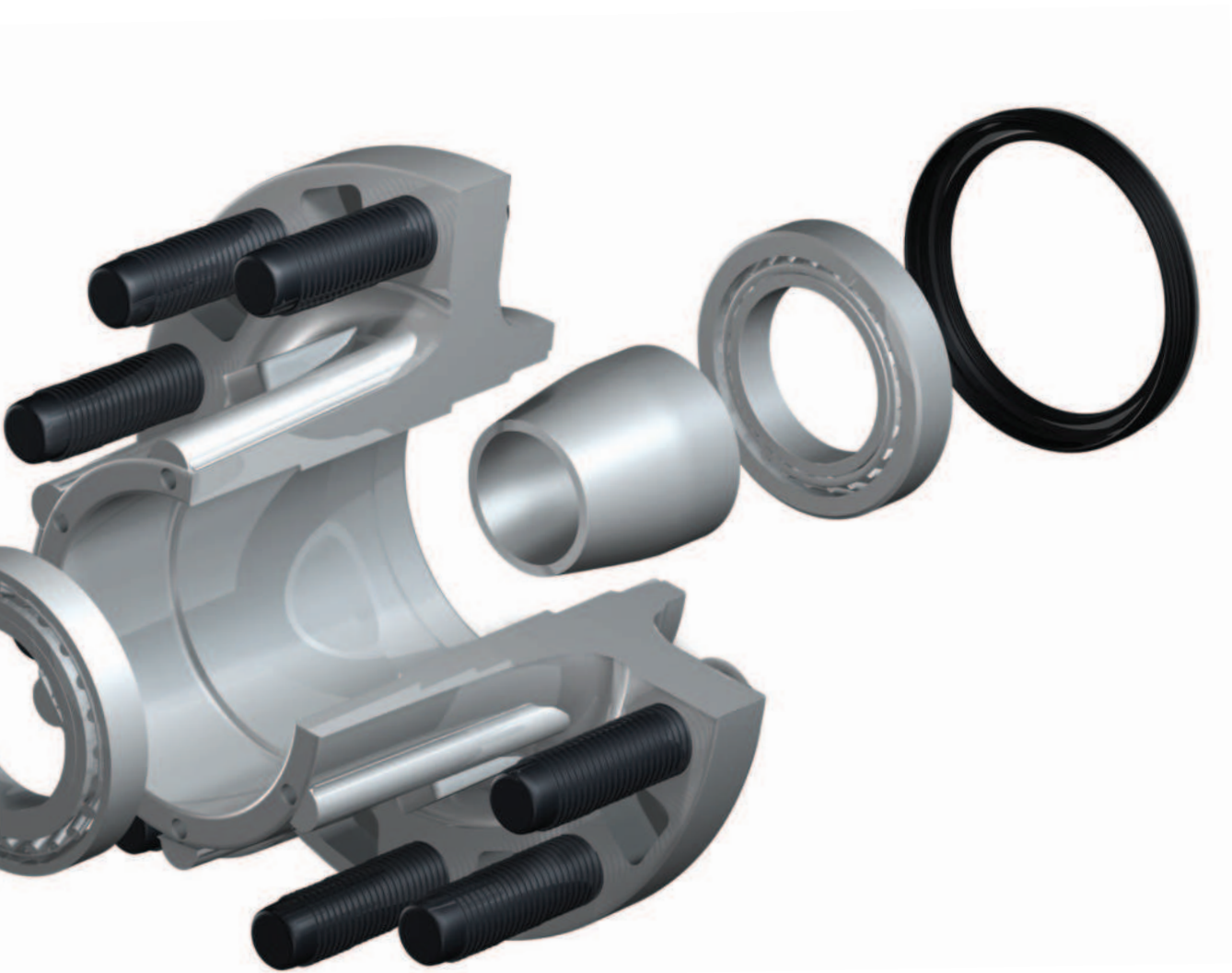

## Why install the kit, instead of off-the-shelf components?

While you could pull the spacer and rebuild your pre-adjusted wheel end with individual components from several suppliers, there are some compelling reasons to install the SKF rebuild kit for pre-adjusted hubs.

**Reduce fleet downtime** – Unlike off-the-shelf components, all of the kit's parts are manufactured to SKF's and ConMet's specifications, ultimately reducing downtime and lowering operating costs.

**Simpler installation** – One procedure regardless of axle type, eliminating potential failures due to error; no need for complicated torquing and use of a dial indicator.

**Extended 3-year warranty** – In addition, by installing the ConMet® approved SKF rebuild kit for pre-adjusted hubs, you will receive an extended 3-year warranty on these SKF wheel end components.

**Longer service life** – Because the kit meets the exact specifications of the original pre-adjusted hub system components, you can expect the same kind of reliability and performance from your rebuilt wheel end.

[See the complete rebuild kit for pre-adjusted hubs part listing on page 61](#)

# Spindle nut locking system



The SKF spindle nut locking system offers a new, robust and affordable lock nut system for tractors and trailers alike. Forged, precision machined and assembled with two high-strength lock bolts, the spindle nut locking system yields one of the strongest systems available today. Coupled with the precision stamped lock washer, this system provides the user with end-play adjustability that exceeds the stringent demand of today's field environment and maintenance requirements.



This system is intuitively easy to install and service, and requires no special tools. The spindle locking nut is now available in steering, drive and trailer sizes.

Hardened washer

Wheel bearing lock nut

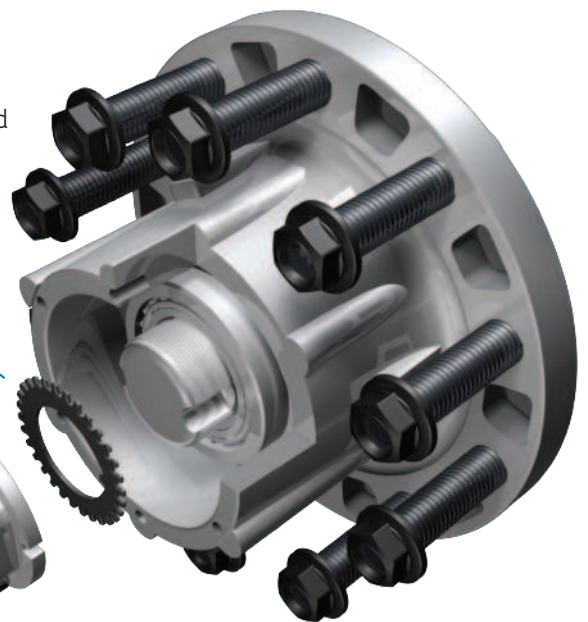

See the complete SKF Spindle nut locking system part listing on page 62

# Two-piece wheel nut

## Turn to a proven supplier for safety-critical wheel end components

The wheel end is critical to highway safety including the driver, cargo and others traveling on the roads. It's always best to trust a proven supplier with safety critical components.

The wheel nut is designed to provide increased clamp force while maintaining optimized torque/tension, reducing operating costs with extended tire life and improved fuel economy.

SKF M22 X 1.5 two-piece wheel nuts, available in 33mm and 38mm OD, fit most tractors and trailers with hub piloted wheels.

### Benefits of the SKF two-piece wheel nut include:

- Reduced potential for catastrophic failure – loosened wheel nuts can result in wheel-off conditions, as well as reduce the operating life of the wheel end's seals and bearings
- Reduced operating costs – wheel nuts effect overall tire life and wheel end life, ultimately reducing fuel usage and costs
- Quality design and manufacturing – manufactured to precise tolerances and meets the stringent requirements of SAE J1965
- Provides increased clamp force while maintaining optimum torque/tension
- Extended nut life – PTFE coating protects against corrosion and reduces friction
- OE first fit wheel nut on many new production units



SKF recommends placing a small bead of oil on the end of each stud before installing the two-piece wheel nut

[See the complete two-piece wheel nut part listing on page 62](#)

# Sleeve nut

## Help reduce wheel and wheel stud damage

The SKF sleeve nut was developed to reduce wheel and wheel stud damage and help prevent unpredictable wheel off situations.

This system is specifically designed for Class 7 and 8 trucks, tractors, trailers and any vehicle that uses M22 X 1.5 two-piece wheel nuts.

Sleeve fills in gap between stud and hole, eliminating “clocking” and damage to studs that can cause wheel-offs.

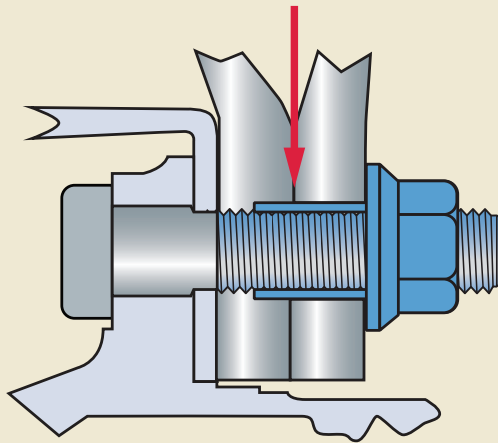

### Benefits of the sleeve nut include:

- Minimizes the clearance between the wheel stud and the wheel bolt hole
- Reduces the movement or “clocking” of loose wheels
- Engages both dual wheels
- Protects and covers the threads from wear
- Slows the process of wheels loosening
- Lengths designed for specific axle applications and wheel configurations



**6 mm sleeve**  
Designed for:

**Steer axles:**  
Steel wheels

**Drive/trailer axles:**  
Steel wide single wheels



**19 mm sleeve**  
Designed for:

**Steer axles:**  
Aluminum wheels

**Drive/trailer axles:**  
Aluminum wide single wheels

**Drive/trailer axles:**  
Steel outer/steel inner dual wheels



**28 mm sleeve**  
Designed for:

**Drive/trailer axles:**  
Steel outer/aluminum inner dual wheels

**Drive/trailer axles:**  
Aluminum outer/steel inner dual wheels



**39 mm sleeve**  
Designed for:

**Drive/trailer axles:**  
Aluminum outer/aluminum inner dual wheels

See the complete SKF sleeve nut part listing on page 62

# Unitized pinion seal

The SKF unitized pinion seals offer the optimum sealing performance with extended life. The superior design provides a perfectly matched running surface for the sealing lips made from highly engineered fluoroelastomer. High temperature capable with extensive exclusion properties provides long life in a highly aggressive application. The unitized design incorporates the patented wave seal that sweeps lubricant back to the bearings promoting cooler running operation. Another innovative feature of this seal adding long life is the 1/2 metal, 1/2 rubber ID allows for heat dissipation while holding a positive grip on the shaft.

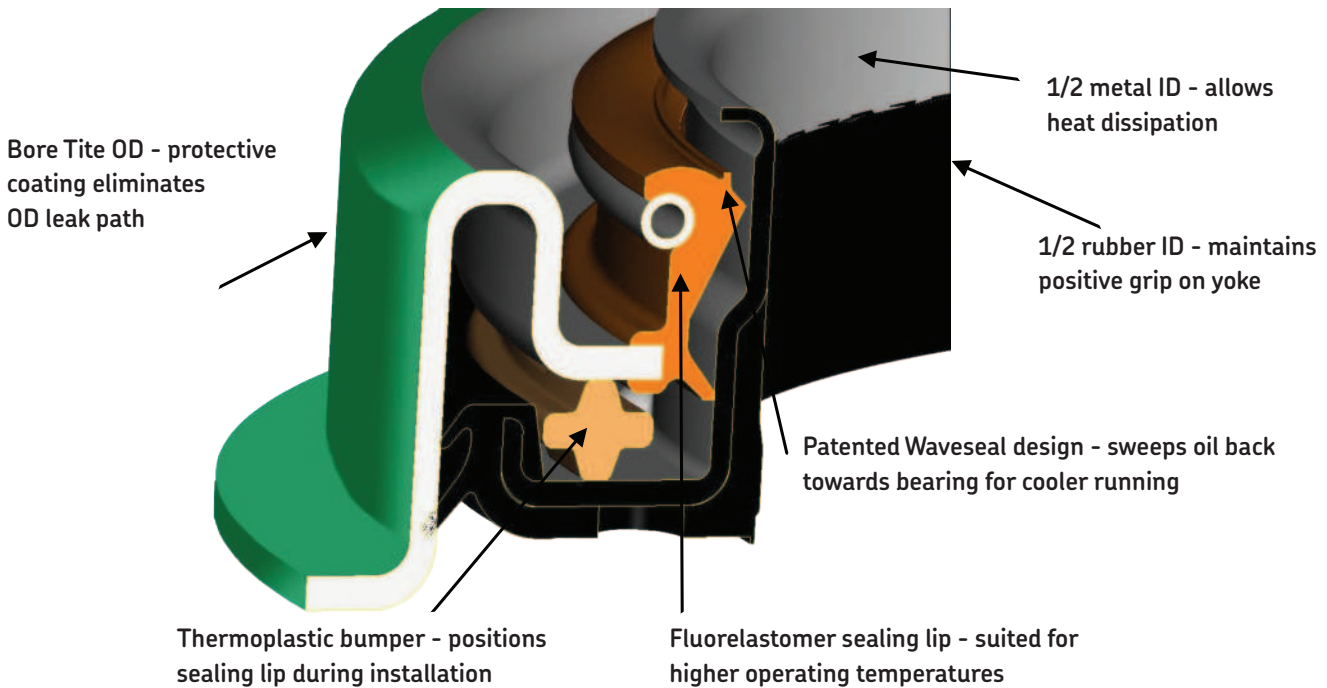

PT6000 tool installs all SKF unitized pinion seals

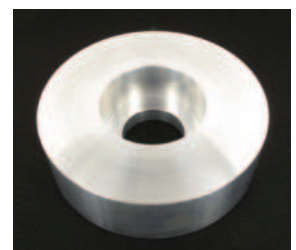

See the complete Unitized pinion seal part listing on page 61

# Tools and accessories

## CR Scotseal *Classic* installation tool

It is recommended that CR Scotseal Classic wheel seals be installed with the CR Scotseal installation tool. Precisely matched centering plugs are engineered to fit within the inside diameter of the inner bearing cone and allow accurate centering of the CR Scotseal Classic in the bore of the hub, as well as preventing cocking of the seal.

See page 63 for a complete listing of drive plates and centering plugs

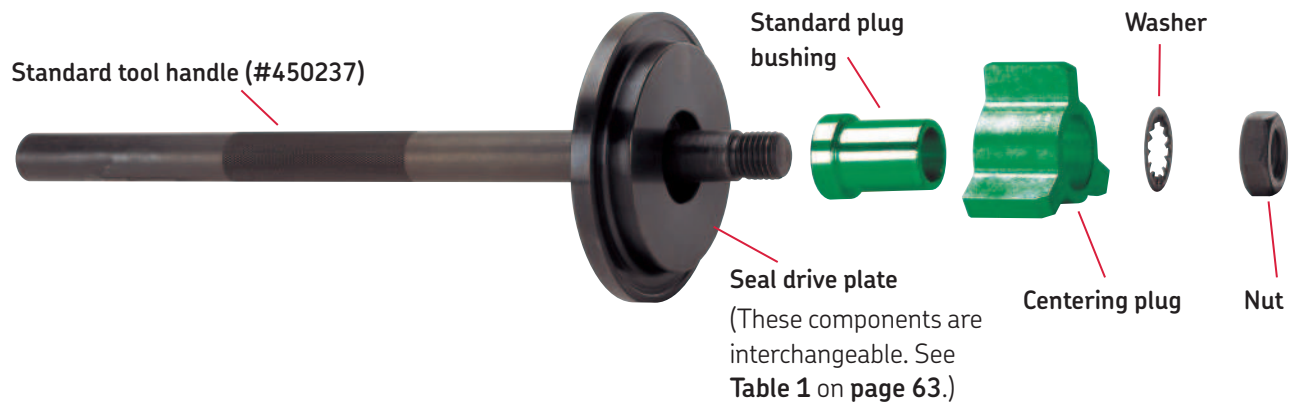

## The Scotseal toolboard

- Keeps tools orderly and lessens chances of tools being misplaced or damaged
- Sturdy metal construction – mounts easily on shop wall
- Fitting chart included
- Just order Part No. TB-2



## SRT-1 Seal removal tool

The SKF SRT-1 Seal Removal Tool is recommended for removal of most tractor, truck, dolly or trailer wheel seals. With the wheel hub assembly removed from the axle, simply insert the hook tip of the tool between the seal and bearing.

- Saves bearings – tool grabs seal only and bearings go undamaged.
- Seal is removed intact allowing for proper seal inspection and failure analysis if required.
- Works with steer, drive, and trailer wheel seals.



## Universal bearing cup installer

The universal bearing cup installer (HD1) from SKF is a three-jaw system that provides evenly distributed pressure, eliminating cocked installations.



## CR Scotseal Hybrid installation tool

Use CR Scotseal Hybrid installation tool (491) and drive the seal on to the spindle until the tool bottoms against the shoulder and the tool ring is flush with the spindle shoulder.



# Krown\*

## Fast, easy solutions to protect vehicles from road debris, salt and rust

Heavy duty trucks endure rugged operating conditions. Protect your investment with the Krown family of lubricants. Available in 55-gallon drums, 5 gallons, and easy to apply aerosol spray cans.

**Krown Corrosion Inhibitor** is formulated to help control corrosion in the most damaging of environments. Unlike many competitive products, this rust inhibitor contains no solvents which are hazardous to the environment, dangerous to the user and damaging to paint, plastic and rubber.



## Tractor service

### Cab-trailer connection

- Fifth wheel mounting area: linkage, locks and slider
- Sliding bogies/Bogie lock
- Frame rails and hardware

### Exterior cab

- Bunk locks
- Door hinges, latches and rollers
- Hood hinges and latches

### Interior cab

- Fuel pedal and base linkage
- Storage box locks/Tool boxes
- Door jambs and internal door hardware

### Under the hood

- Electrical connections: alternator, battery and starter
- Battery hold downs
- Relays and solenoids
- Fuse panels/Circuit breakers

### Other areas

- Light cord ends/sockets
- Fuel tank straps

### Wheel ends

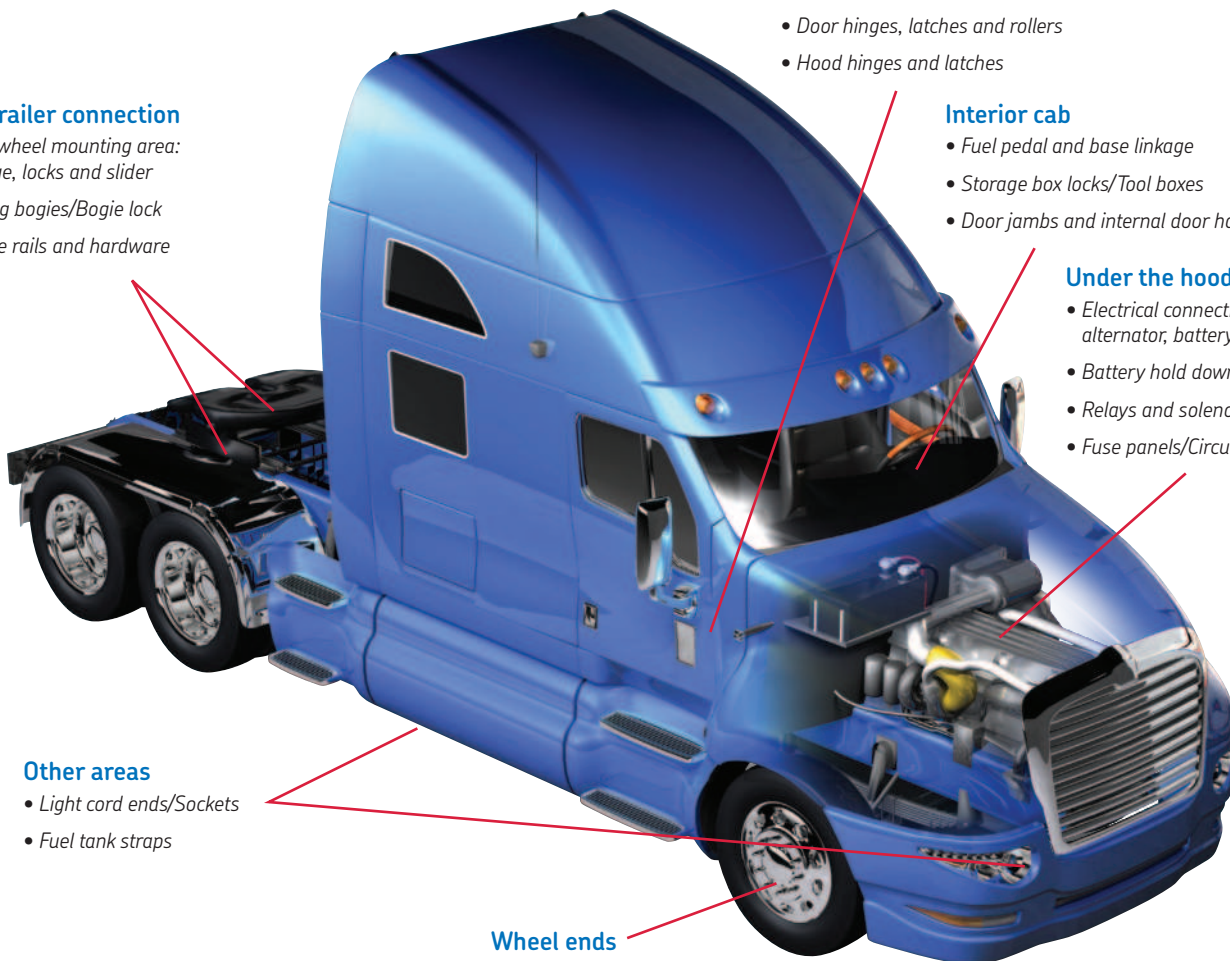

\* Excludes Canadian market

Contact SKF Customer Service or your SKF sales representative to set up a Krown maintenance program.

# Trailer service

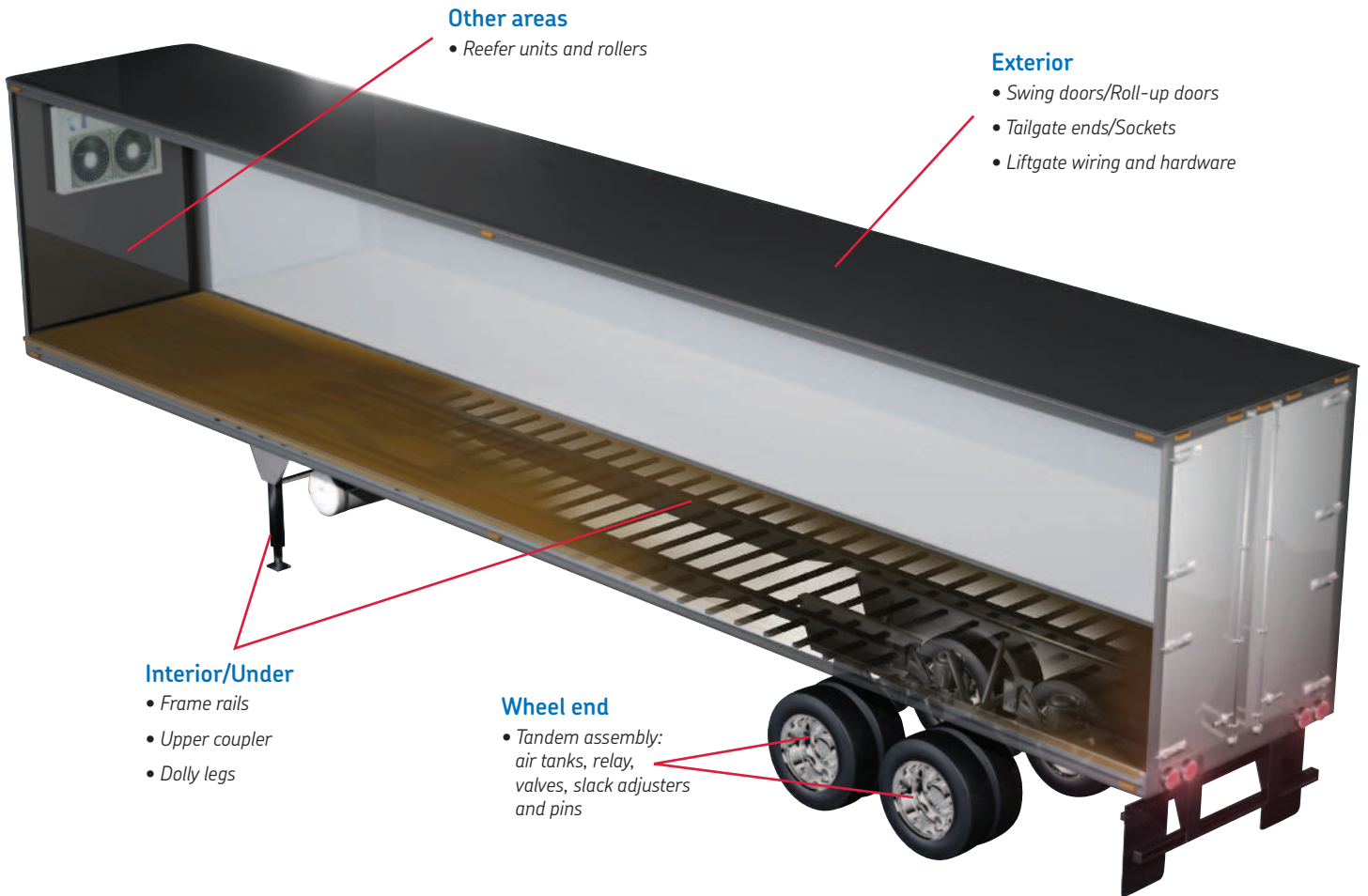

## Other Krown products

**Krown Salt Eliminator** is a very unique, equipment saving, protection product that makes the difficult task of salt removal easy. This proprietary formulation not only dissolves salt much more quickly, but also breaks the bond between chloride and metal while preventing the reforming of these salts after cleaning is complete.



**Krown Fast Acting Penetrant** will rapidly penetrate and loosen seized and rusted parts. This product is a solvent-free penetrant, which means the product remains on surfaces, lubricating and protecting from rust.



**Krown Chain Lubricant** is a solvent-free product designed to substantially enhance chain life while reducing wear and friction. Safe for self-lubricating chain, it will reduce corrosion and help to keep debris from sticking and causing costly repair and downtime. Engineered for high-heat applications.



# Wheel end inspection and maintenance

It is important to inspect a vehicle's wheel ends periodically for safety and to maximize over-the-road performance. SKF recommends inspecting wheel ends every 100,000 miles or every 12 months using SKF's inspection check list found at

[www.vsm.skf.com](http://www.vsm.skf.com). After inspection you may determine that a wheel end repair is necessary.

Pre-adjusted hub assemblies require service at 500,000 miles or every 2nd brake service.



Use a proper supporting device to support the vehicle. Carefully release air spring brakes.



When inspecting wheel ends, be sure to block wheels and lift axle.

**WARNING: Never work under a unit supported by only a jack. Always support the vehicle with stands. Block the wheels and make sure the unit will not roll before releasing brakes. Always wear eye protection.**

## Helpful hints before you start

- Stay organized—a messy shop is dangerous and inefficient
- Keep loose components together
- It is important to not mix wheel-end components – bearings are “mates” that wear together. This includes new bearings
- Do not use chisels, impact wrenches and torches
- Do not use hammers directly on seals or bearings

## Hub removal

Using a proper hub support, remove spindle nut and pull hub assembly off spindle.



# Inspection of spindle and hub

It is important to inspect a vehicle's wheel ends periodically for safety and to maximize over-the-road performance. SKF recommends inspecting wheel ends every 100,000 miles or every 12 months using SKF's inspection check list found at

[www.vsm.skf.com](http://www.vsm.skf.com). After inspection you may determine that a wheel end repair is necessary.

Pre-adjusted hub assemblies require service at 500,000 miles or every 2nd brake service.

## 1 Inspect the spindle and spindle threads for damage, and remove light fret. Also check for the following:

- Spalling
- Corrosion pits
- Discoloration from overheating
- Punch marks / chisel marks
- Weld beads
- Upset metal

**NOTE:** Damaged threads can be repaired using a pitch thread file or die nut.

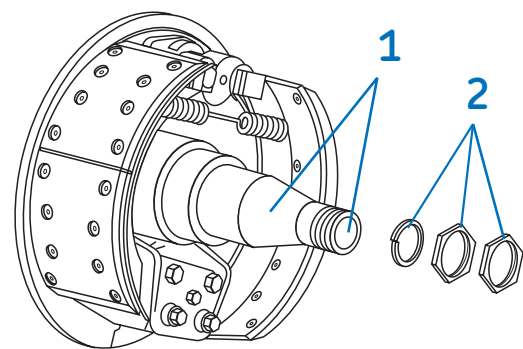

## 2 Inspect the fastener / Locknut / Bearing adjustment nut / Washer

(The use of these spindle end components varies by truck or trailer manufacturer. See illustrations below of the various nut systems you may encounter.)

Look for chisel marks or other deformation as a sign of improper installation, or an attempt to make temporary repairs.

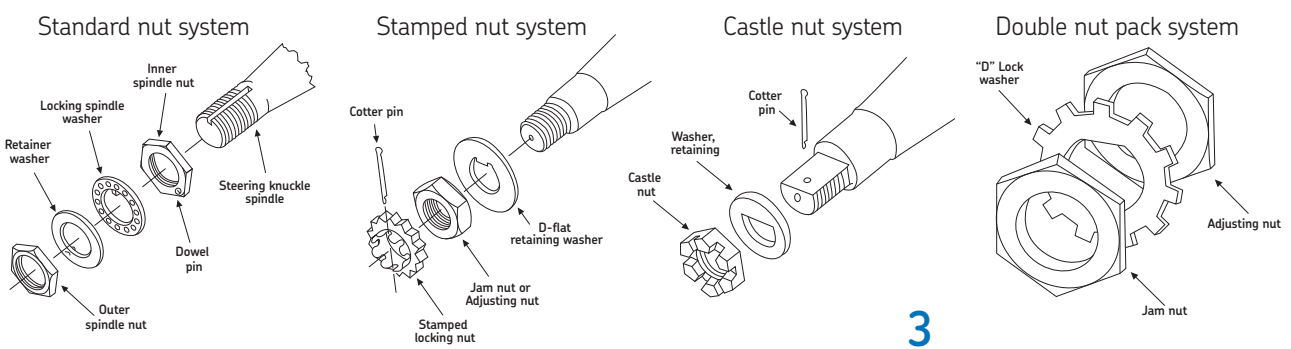

To learn about the one-piece SKF spindle nut locking system, see page 16

## 3 Inspect the inside and the outside of the hub. Look for the following:

- Broken fasteners / bolts
- Cracks in the housing
- Damage to the hub and bore

**NOTE:** If the bearing cup is loose in the hub, this indicates a serious condition and the hub must be replaced.

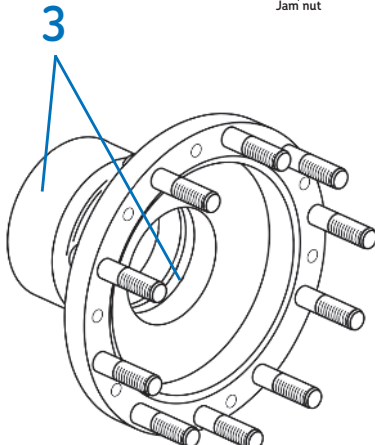

# Seal and bearing removal

The SKF SRT-1 Seal Removal Tool is recommended for removal of most tractor, truck, dolly or trailer wheel seals. With the wheel hub assembly removed from the axle, simply insert the hook tip of the tool between the seal and bearing. The unique design of the tool allows you to use leverage to easily and safely remove the seal, without damaging the spindle.

Remember performing seal failure analysis will ensure improved performance. See **pages 40-49** for seal failure analysis information.

**WARNING:** Do not add a handle extension to the tool. This tool is to be used for seal removal only.



# Bearing inspection

Once the seal is removed, inspect the bearing cone and cup for any nicks, burrs or spalling. Reference the bearing failure analysis section in the back of this guide. See **pages 50-56**.

Bearings must be cleaned for inspection and can be re-used. Use only clean solvents – effectiveness of solvent in removing old lubricant depends on how clean the solvent is.

Good cleaning requires proper equipment such as:

- A solvent bath
- A filter system and regular changes of the solvent and the filters

**NOTE:** Do not allow bearing to sit on the bottom of the container to avoid contact with sediment.



## Bearing cup removal

If the bearing cone or cup is damaged, you must replace both. To remove the cup, follow one of the procedures below based on the type of hub you are working with.

### Ferrous hubs:

Use hydraulic press

### Aluminum hubs:

Weld bead around face of the bearing cup. Allow to cool for 15 minutes and remove. **DO NOT USE hydraulic press.**

# Bearing installation

There are two main types of serviceable wheel hub assemblies – manually adjusted and pre-adjusted. The re-assembly instructions are different for both so be sure to follow the correct procedure for each wheel end type.

The pre-adjusted hub assembly includes a spacer between the inner and outer bearings. The bearings are specially toleranced in order to achieve the targeted adjustment setting.

The specific installation instructions for pre-adjusted hubs are included in the SKF rebuild kit for PreSet® and can also be found on-line at [www.vsm.skf.com](http://www.vsm.skf.com).

Care in handling components and proper tooling are always the critical factors in all procedures which lead to trouble-free operation.

## Bearing installation

Bearing installation is handled differently depending on whether you are working with a ferrous hub or an aluminum hub. With either hub, never directly hammer on the bearing.

### For ferrous hubs:

Use the SKF HD1 tool to install the bearing cups into the hub.

### For aluminum hubs:

Heat the hub in boiling water or in an oven to no more than 300° F. Do not use localized heat. Chill the bearing cup in a freezer. The hub will expand and the cup will contract. Place the cup into the hub.

For oil lubricated wheel ends, coat the bearing cones with a light oil film before inserting them into the hub. Always use the same lubricant being retained in the hub. Do not mix lubricants. Install the inner bearing cone into the hub.



# Seal installation

## CR Scotseal *X-Treme* and CR Scotseal *PlusXL*

This seal is hand installable. No special tools are required.

**Caution:** Do not install the CR Scotseal X-Treme or CR Scotseal PlusXL directly onto the spindle.

Place the hub (wheel) assembly flat or at least a 45° angle for seal installation. Clean bore of any particles, rust or grease.

- 1 Pre-lube the inner bearing cone with the lubricant that is being retained and place it into the hub.
- 2 Lightly lubricate the seal O.D. and I.D. evenly with the fluid that is being retained. Also apply a thin layer of oil on the hub bore that the seal is being pressed into. NEVER INSTALL DRY.
- 3 Press the seal by hand evenly into the bore. A rubber mallet or other soft-faced tool may be used to gently tap the seal into place. Be sure that the seal is evenly seated and bottomed in the bore. As in any seal installation, apply an even driving force to avoid cocking the seal or damaging the flange surface.
- 4 Allow seal to set for about 5 minutes prior to installing hub assembly onto spindle.

**Caution:** Install a new seal if the seal is cocked or damaged during or after installation.



Watch the Scotseal PlusXL installation video.



Lightly lubricate the OD and ID with the fluid being retained



Press the seal into the bore evenly by hand



A rubber mallet may be used to tap into place

## CR Scotseal Hybrid

When installing the CR Scotseal Hybrid, it is important to use SKF tool 491 to set the seal correctly onto the spindle.

- 1** Inspect the entire spindle, including the threads, making sure there are no worn spots, burrs or etching. After removing the old wear ring, clean any sealant off of the shoulder surface with emery cloth if needed. Clean the entire wheel cavity. Place seal assembly on spindle shoulder with "Oil Bearing Side" facing out.

**Warning:** DO NOT install the seal into the hub bore. DO NOT use sealant on Inside Diameter (ID). SKF seals have an acrylic polymer green coating (Bore Tite) applied to the ID. Adding sealant may adversely affect the seal installation & performance.

- 2** Use SKF tool 491. Drive seal assembly on to spindle until tool bottoms against the shoulder and tool ring is flush with the shoulder. **Warning:** Remove any green Bore Tite that scrapes onto the spindle during installation to prevent the acrylic polymer coating (Bore Tite) material from getting into the bearing assembly.
- 3** Apply lubricant to inner bearing and install onto spindle. Use oil or pack with grease prior to installation.
- 4** Apply a thin coat of the same lubricate used in the wheel end to the Outside Diameter (OD) of the seal prior to wheel installation.



Place seal on spindle shoulder 'Oil Bearing Side' out



Use SKF tool 491 on spindle



Drive seal onto spindle



Apply lubricant being used onto OD of seal

# Seal installation

## CR Scotseal *Classic*

When installing a CR Scotseal Classic seal, it is important to use the proper installation tool to set the seal correctly into the hub. The SKF installation tool is specifically contoured to fit the profile of the seal.

**Caution:** Do not install the CR Scotseal Classic directly onto the spindle.

Place the hub (wheel) assembly against a solid surface or bench at a 45° angle for seal installation. This aids in centering the bearing and seal in the hub bore. Clean bore of any particles, rust or grease.

- 1** Pre-lube the inner bearing cone with the lubricant that is being retained and place it into the hub.
- 2** Place the CR Scotseal Classic into the hub bore and insert the tool assembly with centering plug into the seal. Note: Be sure to wear proper eye protection.
- 3** Hold the tool handle firmly and straight, and drive the seal with firm hammer strokes until the seal is squarely seated. Continue driving the seal into the hub until the sound of impact changes.
- 4** After the seal is bottomed in the bore, check for freedom of movement by manually moving the packing of the seal up and down. Ensure that the inner bearing rotates freely.

**Caution:** Install a new seal if the seal is cocked or damaged during or after installation.

For detailed information about the CR Scotseal Installation tools, see **pages 20-21**.

For drive plates and seal match-ups, see **Table 1** on **page 63**.

For match-up of bearing cones and centering plugs, see **Table 2** on **page 63**.



Watch the CR Scotseal Classic installation video.

# Installing hub assembly

- 1** When installing the hub assembly over the axle spindle be sure to align the hub bore to the center of the spindle. Mechanical supports will allow you to do this without scraping or otherwise damaging the spindle, the threads and in particular the seal.
- 2** Install the outer bearing cone and adjusting nut. Tighten nut only until it is snug against the bearing cone. **DO NOT USE A PNEUMATIC TOOL** during this part of the procedure. Be sure to maintain support of the hub assembly until the adjusting nut is secure. Failure to do so may cause damage to the seal and subsequent leakage of lubricant.
- 3** Remove the hub support so that the hub is resting on the bearings. Check for free rotation of the bearings. Never allow hub to rest on seal.
- 4** Follow wheel bearing adjustment as instructed on following page.

## WARNING

**Do not attempt to install the hub assembly by hand! Whether the hub is with or without the tire, do not install it without mechanical support.**

Axle spindle (shaft)

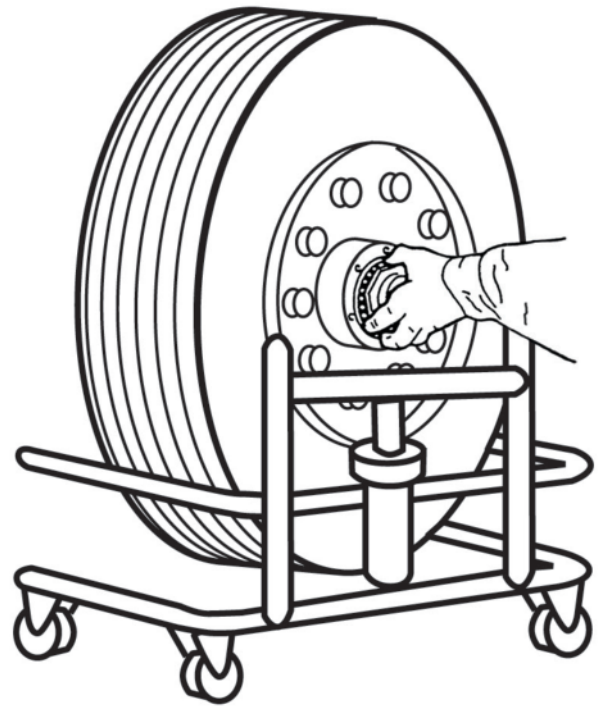
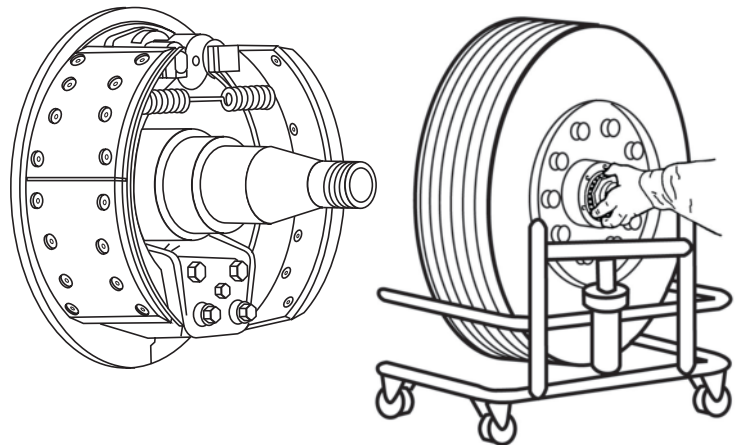

# Wheel bearing adjustment procedures

## Manual wheel bearing adjustment procedure\*, 3)

**Step 1:** Lubricate the wheel bearing with clean axle lubricant of the same type used in the axle sump or hub assembly.  
**Note:** Never use an impact wrench when tightening or loosening lug nuts or bolts during the procedure.

Initial adjusting nut torque	Initial back off	Final adjusting nut torque	Axle type	Threads per inch	Final back off	Nut size	Torque specifications	Acceptable end play
<b>Step 2</b>	<b>Step 3</b>	<b>Step 4</b>	<b>Step 5</b>		<b>Step 6</b>	<b>Step 7</b>		<b>Step 8</b>
200 lb-ft (271 N-m) While rotating wheels	One full turn	50 lb-ft (68 N-m) While rotating wheels	Steer (front) non-drive	12	1/6 Turn <sup>1)</sup>	Install cotter pin to lock axle nut in position	200–300 lb-ft (271–407 N-m)	0.001 in – 0.005 in (0.025 mm–0.127 mm) As measured per procedure with dial indicator
				18	1/4 Turn <sup>1)</sup>			
				12	1/3 Turn <sup>1)</sup>			
				14	1/2 Turn			
			18					
			Drive	12	1/4 Turn	Dowel type washer	300–400 lb-ft (407–542 N-m)	
				16		Tang type washer <sup>2)</sup>	200–275 lb-ft (271–373 N-m)	
			Trailer	12	1/4 Turn	Less than 2 5/8 in (66.7 mm)	200–300 lb-ft (271–407 N-m)	
				16				

<sup>1)</sup> If dowel pin and washer (or washer tang and nut flat) are not aligned, remove the washer, turn it over, and reinstall. If required, loosen the inner (adjusting) nut just enough for alignment.

<sup>2)</sup> Bendable type washer lock only: Secure nuts by bending one wheel nut washer tang over the inner and outer nut. Bend the tangs over the closest flat perpendicular to the tang.

<sup>3)</sup> See pages 34-35 for SKF lock nut system procedure

\* Printed with permission of the TMC, Reference RP618B

## Pre-adjusted wheel bearing adjustment procedure

**This refers to torque specifications and bearing adjustments. Please refer to original equipment manufacturer’s recommended procedures for complete installation details.**

**One piece spindle nuts** - Torque a one piece spindle nut to 300 ft. lbs. while rotating the hub. **Do not back off the spindle nut.** Engage any locking device that is a part of the spindle nut system. If the locking device can not be engaged, advance the spindle nut until the lock can be engaged.

**Double jam nut systems** - Torque the inner spindle nut to 300 ft. lbs. while rotating the hub. Advance the inner nut as necessary to engage the locking ring. **Do not back off the spindle nut.** Install the outer spindle nut and torque it to 200 ft. lbs. Be sure to engage any locking device.



# PreSet / PreSet Plus wheel bearing adjustment procedure

**Step 1:** Lubricate the wheel bearing with clean axle lubricant of the same type used in the axle sump or hub assembly.  
**Note:** Never use an impact wrench when tightening or loosening lug nuts or bolts during the procedure.

Initial adjusting nut torque	Initial back off	Final adjusting nut torque	Axle type	Threads per inch	Final back off	Nut size	Torque specifications	Acceptable end play
Step 2	Step 3	Step 4	Step 5		Step 6		Step 7	
While rotating tire	None	300 lb-ft Inner	Drive	N/A	No Back Off	PreSet 2 piece nut (FF, FL, R, TN, TP, L)	300 lb-ft Inner	300 lb-ft Minimum Advanced to nearest lock
		200 lb-ft Outer				PreSet 2 piece nut (FF, FL, R, TN, TP, L)	200 lb-ft Outer	200 lb-ft Minimum Advanced to nearest lock
		150 lb-ft Inner	Steer			PreSet 2 piece nut (F Medium Duty)	150 lb-ft Inner	150 lb-ft Minimum Advance to nearest lock
		100 lb-ft Outer				PreSet 2 piece nut (FC Medium Duty)	100 lb-ft Outer	100 lb-ft Minimum Advance to nearest lock
		300 lb-ft	Steer / Drive / Trailer			PreSet 1 piece nut (FF, FL, R, TN, TP, L)	300 lb-ft	300 lb-ft Minimum Advance to nearest lock
		150 lb-ft	Steer			PreSet 1 piece nut (FC Medium Duty)	150 lb-ft Inner	150 lb-ft Minimum Advance to nearest lock
		500 lb-ft	Drive & Trailer			PreSet Plus <sup>1</sup>	500 lb-ft	500 lb-ft Minimum Advance to nearest lock
		300 lb-ft	Steer			PreSet Plus <sup>1</sup>	300 lb-ft	300 lb-ft Minimum Advance to nearest lock

<sup>1)</sup> PreSet Plus nut assembly and spiral snap ring (where present) must be in place.

# Wheel bearing lock nut system installation and adjustment procedures

**NOTE:** The SKF spindle nut locking system used on preset hub designs should be installed following the current torque specifications of the preset hub manufacturer's instructions.

**WARNING:** This instruction sheet is for manual adjustment of taper roller bearings. Failure to follow these instructions when doing adjustments on conventional wheel ends may cause the wheel to come off and cause bodily injury and/or property damage.

- 1 Ensure all wheel end components are assembled and pre-lubricated, if required, to their respective manufacturer's warranty, quality, care, and assembly instructions. **Care must be taken not to lubricate spindle threads. False torque readings will occur if spindle threads are lubricated.**
  - a) Ensure all bearings, hub bores and spindles are cleaned, inspected and prepared per TMC RP622.
  - b) Ensure that the spindle keyway is clear of interference all the way to the bearing journal and that the spindle threads are without damage and functional all the way to the bearing face.
- 2 Install the wheel bearing lock washer as shown in Figure 1. Washer tab must be engaged in keyway and pushed deep on spindle until it contacts and moves the outboard bearing into its hub mounted race.
- 3 The lock nut can now be threaded onto the spindle, as shown in Figure 2, and tightened by hand.
- 4 Using a six-point thin tubular socket with the appropriate **calibrated torque wrench**, torque nut to 200 ft-lbs. while rotating the wheel. See Table 1 for wrench sizes. After torque is achieved, rotate wheel hub assembly an additional two full revolutions. **(Wheel should not rotate freely at a nut torque of 200 ft-lbs)** See Figure 3 for socket placement.
- 5 Without disturbing the wheel/hub, back off the lock nut one full turn. Rotate the wheel.
- 6 Re-torque SKF spindle wheel nut to 50 ft-lbs while rotating the wheel.
  - a) Rotate two full additional revolutions
  - b) Back the nut off the appropriate number of washer notches according to Table 2 using the sight-gage in flange of nut.
  - c) Verify bearing end play of .001 to .005 of an inch using process in step #10 of this procedure.
  - d) If end play CANNOT be verified, repeat steps 4 through 6.

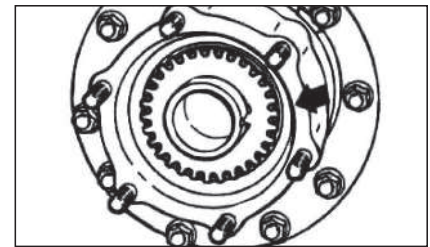

Figure 1

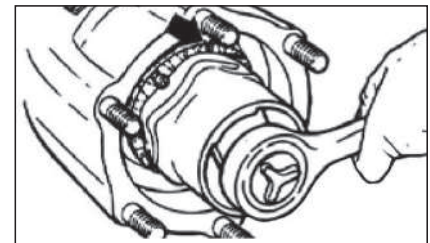

Figure 2

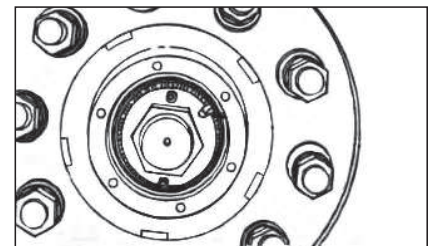

Figure 3

Table 1

Nut thread size	Wrench hex size
1.50 - 12	2"
1.50 - 18	
2.625 - 12	3"
2.625 - 16	
3.25 - 12	3 3/4"
3.48 - 12 Special	3 3/4"
3.48 - 12	4 1/8"
3.50 - 12	

Table 2

Axle type	Thread size	Final back off
<b>Steer (front) Non-drive</b>	1 1/2" - 12	3 washer notches
	1 1/2" - 18	4 washer notches
<b>Drive</b>	2 5/8" - 12	4 washer notches
	3 1/4" - 12	3 washer notches
<b>Trailer</b>	1 1/2" - 12	3 washer notches
	2 5/8" - 16	4 washer notches
	3 1/4" - 12	3 washer notches
	3.48" - 12	3 washer notches
	3 1/2" - 12	3 washer notches

- 7 When end play is verified it is time to arm the wheel bearing lock nut system for field use. Without disturbing the wheel/hub, locate the slot cut in the flange of the wheel nut. This slot is an alignment sight gage for the SHCS (Socket Head Cap Screws) harmonic proof locking system. See Figure 4.
- 8 If sight gage slot aligns with washer slot, tighten and torque SHCS locking system as indicated in step #9. If sight gage slot does not align with washer slot, rotate nut clockwise until alignment occurs, then tighten and torque SHCS locking system as indicated in step #9.
- 9 When nut sight gage and lock washer slot alignment occurs the SHCS locking system can be torqued to a final reading of 41 in-lbs MAXIMUM using a 9/64 hex bit socket for 1.50-12 and 1.50-16 and for all others 143 in-lb MAXIMUM using a 3/16 hex bit socket and the appropriate calibrated torque wrench. **(Make sure heads of cap screws contact nut flange surface) Hub should rotate freely after SHCS locking system is armed. SHCS must be replaced with each and every removal of the wheel bearing lock nut system with a replacement cap screw and using Loctite® threadlocker on the threads.** See Figure 5 for SHCS location.

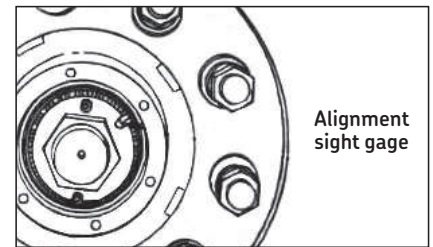

Figure 4

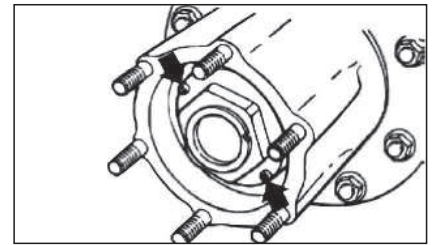

Figure 5

- 10 The following procedure can be used to verify end play:
- Make sure the brake drum to hub fasteners (wheel lug nuts) are tightened to the correct torque.
  - Clean off all surfaces of the exposed axle end and the hub face.
  - Setup gauging with similar equipment as shown in Figure 6.
  - Set the dial indicator to zero. (Gauge must be mounted to the hub and the indicator must be zeroed out on the spindle)
  - Grasp the hub/drum assembly at the 3 o'clock and the 9 o'clock positions. Push the assembly straight in, then straight out while reading the indicator.  
**DO NOT** rock or rotate the hub/drum assembly as an incorrect reading will result. Wheel bearing end play is the total movement of the dial indicator.  
**(TMC RP618 recommends oscillation of the wheel while pushing it in and out.)**
  - Bearing end play must be at least .001 of an inch and not greater than .005 of an inch.**

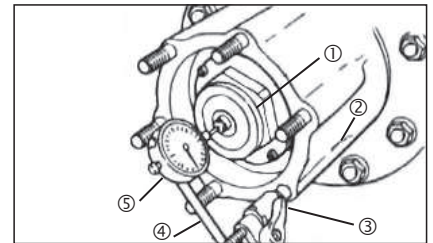

Figure 6

- Magnetic drive axle end plate
- Female adapter mounting rod
- Sliding swivel
- Dial indicator mounting rod
- Dial indicator

® Loctite is a registered trademark of Henkel. All trade names referenced are the service mark, trademark, or registered trademark of the respective manufacturer.

# Wheel bearing end play verification

Wheel bearing end play is the free movement of the wheel assembly along the spindle axis. It is recommended, for verification purposes, that wheel bearing end play be measured with a dial indicator. (Example in photo at right.)

- Step 1** Make sure the brake drum to hub fasteners are tightened to the manufacturers' specifications.
- Step 2** Attach a dial indicator with its magnetic base at the bottom of the hub or brake drum.
- Step 3** Adjust the dial indicator so that its plunger or pointer is against the end of the spindle with its line of action approximately parallel to the axis of the spindle.
- NOTE:** For aluminum hubs, attach the magnetic base of the indicator to the end of the spindle with the plunger against the hub or brake drum.
- Step 4** Set the dial indicator to zero by rotating the gauge face so the zero mark lines up with the gauge needle. For digital indicators, push the zero-out button.
- Step 5** Grasp the wheel assembly at the 3 o'clock and 9 o'clock positions, while oscillating it to seat the bearings. Read bearing end play as the total indicator movement.

**NOTE:** If end play is not within specifications, refer to the readjustment procedure on **pages 32-34** depending on the lock nut system.

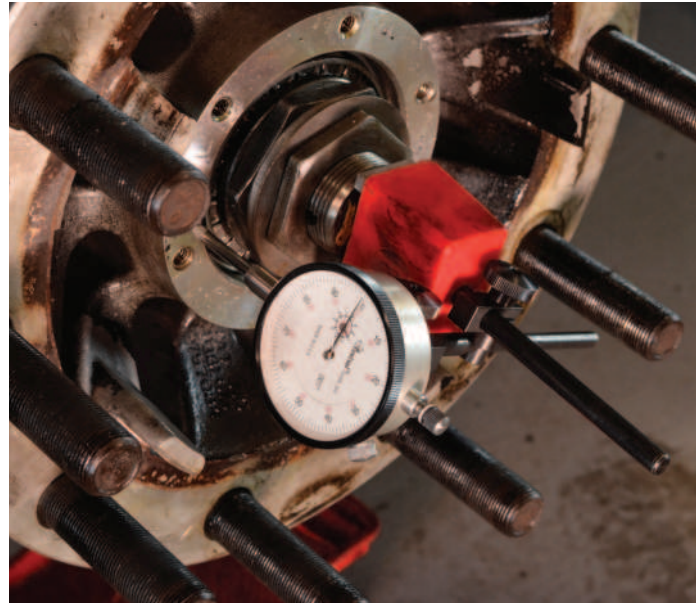

Printed with permission of the TMC, Reference RP618.

Bearing life chart

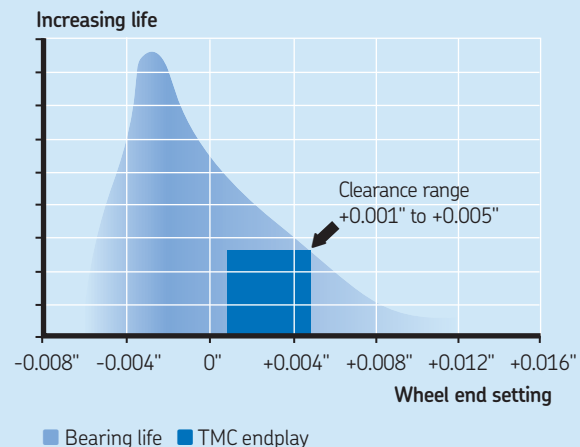



# TFO “Good practice” tips

Our experience has shown that there are many causes of wheel end leakage beyond the oil seal. If you look, you will find that leaking wheel ends leave clues pointing to which component or components are the culprits. Follow the guidelines of the checklist below as you service the wheel end. You may find that just changing the seal may not be your permanent solution.

To prevent wheel end leakage problems, be a good detective ... look for clues.

## Inspect for indications of leakage:

### Under vehicle inspection

- Oil present past the seal
- Oil contaminated hub, brake hardware, brake shoes

### External leakage

- Oil present around hubcap, in wheel cavity
- Oil present around axle flange (drive axle)

### Disassembling the wheel end

*(Caution: Block wheels, support vehicle on stands)*

- Check condition of hubcap. Check flange, window and centerfill plug
- Check bolts and axle flange area on drive axle

### Remove hubcap

*(Axle flange on drive axle)*

### Check condition of lube

- Cloudy or milky indicates water
- Shiny indicates bearing wear
- Metal flakes present could indicate loose shavings from an axle component
- Grit and sand indicates lube contamination
- Smells burnt indicates overheating

### Check condition of fastening system

- Verify end-play measurement before removing fastener
- Examine outer nut, washer (dowel, tang or 'D' type), inner nut, cotter pin

### Remove outer bearing

- Inspect for signs of damage

*Remove wheel or hub assembly, using a wheel dolly*

### Check spindle

- Threads damaged
- Chamfer damaged

Set bearings aside for inspection

### Remove seal

- Check hub
- Condition of chamfer
- Nicks, burrs, damage
- Consult the Failure Analysis section of the User's Manual

# The importance of proper lubricants

Running conditions (Road surface, weather, terrain, speed and load)



## Inspection of lubricant

Inspection of grease or oil can provide a clue to other problems. Remove a sample from the wheel end and check for the following:

- Presence of contaminants
- Burnt aroma
- Presence of water



## Grease and oil lubricants

The truck or trailer manufacturer has pre-determined that the wheel-end assembly is to be lubricated by grease or oil. The importance of following the manufacturer's specifications cannot be over emphasized – never change or mix grease and oil in the same assembly!

**Always use lubricants as recommended by the manufacturer.**

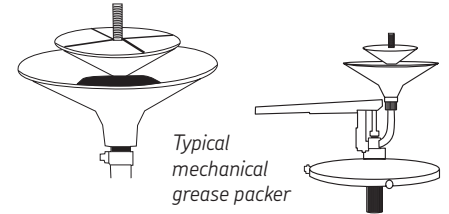

## Grease lubricated wheel ends

Wheel end lubricants are formulated to match the requirements of the truck and bearing manufacturer.

- Always use specified lubricant
- Do not mix lubricants
- Chemical interaction between lubricants and seal materials can damage the seal
- Whenever possible, use a grease packer

**Prior to re-installing bearings, always check for the proper lubricant.**

Wheel end lubricants are formulated to match the requirements of the truck and bearing manufacturer.

- Always use specified lubricant
- Do not mix lubricants
- Chemical interaction between lubricants and seal materials can damage the seal
- Whenever possible, use a grease packer

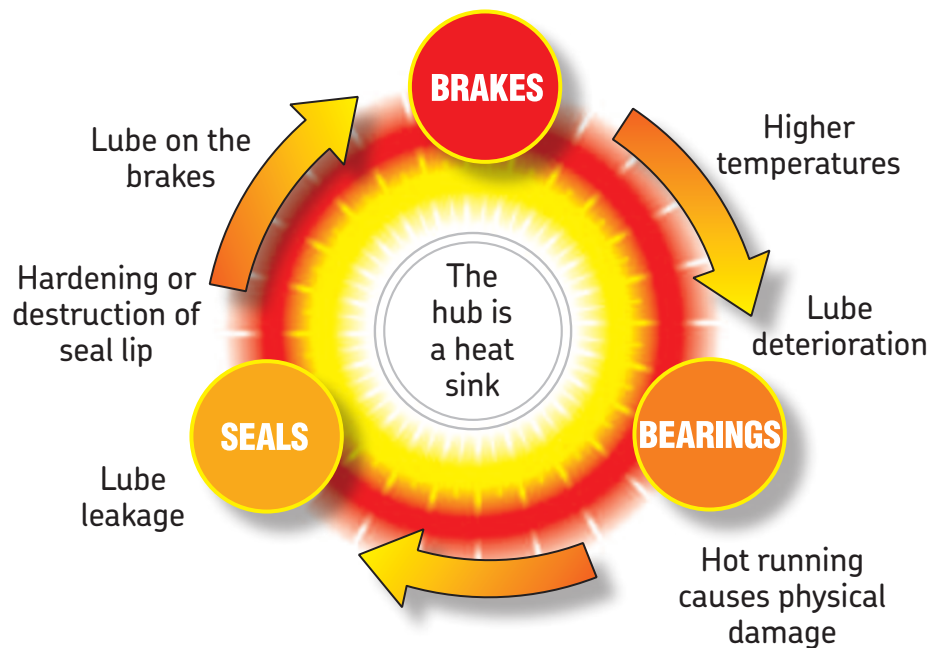

# Failure analysis:

## An important step in achieving wheel end TFO.

Failure analysis of prematurely failed seals is one of the best means to discover the cause of failure and to avoid a similar fate for the replacement seal.

The cross sectional drawings at right illustrate the critical components of the CR Scotseal X-Treme and CR Scotseal PlusXL. The captions identify these components as described in the following pages.

For CR Scotseal X-Treme and CR Scotseal PlusXL, failures most likely result from these common errors:

- Improper installation
  - O.D. and/or I.D. not lubed
- Lube contamination
- Spindle not fully prepped
- Use of a hammer

**NOTE:** replacing a narrow footed seal like the CR Scotseal Classic requires cleaning the spindle along the new area where the wider CR Scotseal X-Treme or CR Scotseal PlusXL will sit.

Consult the following pages for examples of failure analysis.

CR Scotseal *X-Treme*

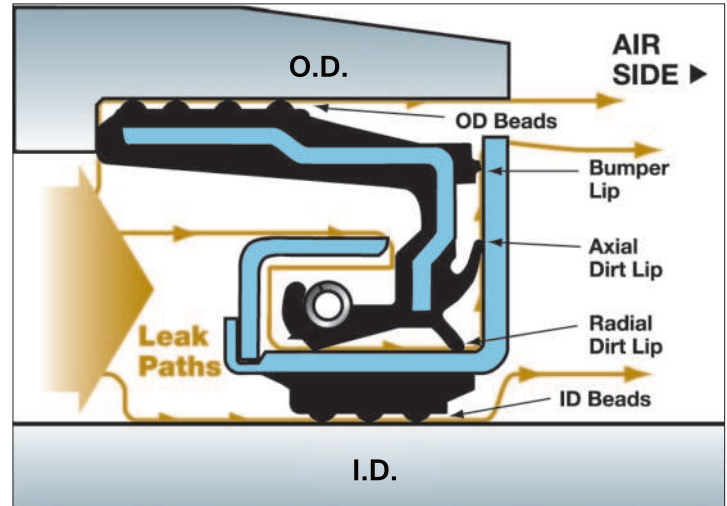

CR Scotseal *PlusXL*

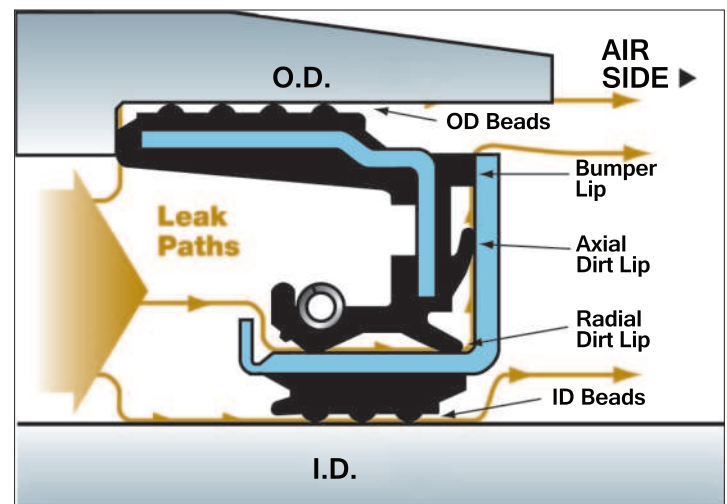

# Failure analysis:

The cross sectional drawings at right illustrate the critical components of the CR Scotseal Hybrid and CR Scotseal Classic. The captions identify these components as described in the following pages.

For CR Scotseal Hybrid, failures most likely result from these common errors:

- Hub imperfections
- Improper installation
  - *Wrong tool or no tool used*
  - *O.D. not lubed*
- Lube contamination
- Spindle not fully prepped or damaged
- Cocked installation

Below are the key failure modes for CR Scotseal Classic. These account for the lion's share of premature seal failures.

- Improper installation
  - *Wrong tool or no tool used*
- Cocked installation
- Lubricant contamination
  - *Metal flakes*
  - *Dirt or water*
  - *Mixing of lube types*
- Improper bearing adjustment
- Seal spinning on spindle
  - *Damaged spindle*
- Hub imperfections
- Installed over a wear ring

[Consult the following pages for examples of failure analysis.](#)

## CR Scotseal *Hybrid*

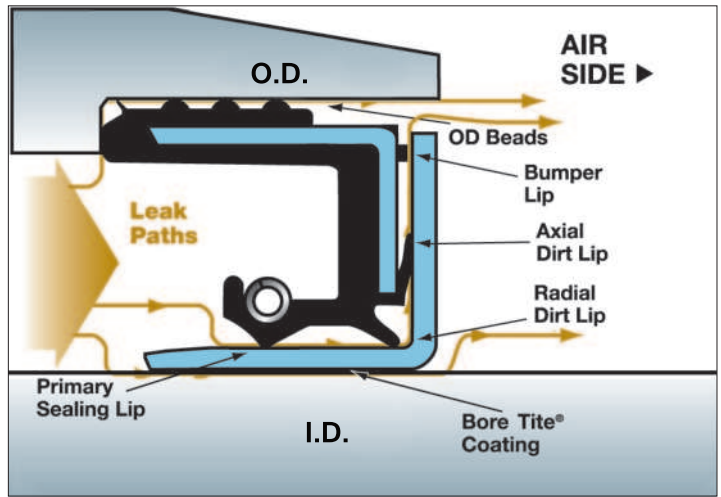

## CR Scotseal *Classic*

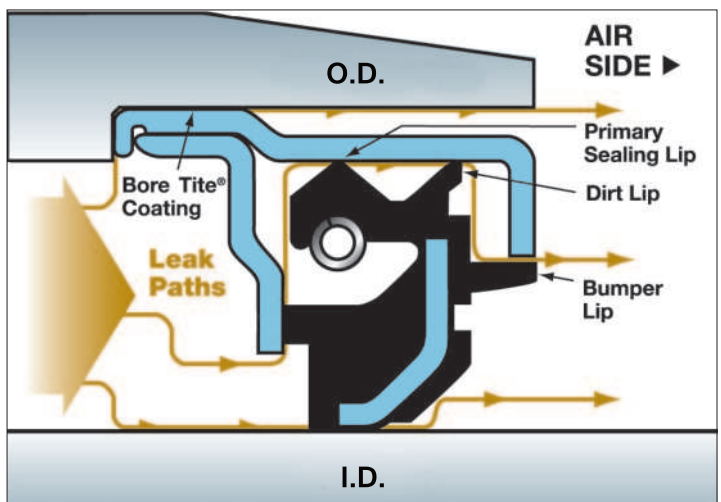

# Failure analysis:

## CR Scotseal *X-Treme* and CR Scotseal *PlusXL*

### External inspection – checking the beads



#### **Normal exterior**

The tough nitrile covering on the CR Scotseal X-Treme or CR Scotseal PlusXL doesn't supply clues as readily as Bore Tite does. But it can still reveal problems and lead to corrective measures. There should be lubrication in each of the O.D., I.D. beads.



#### **Dry exterior**

If, in good illumination, you cannot see any residual lubrication between the beads of the outer sleeve, the seal may have been installed dry. A CR Scotseal X-Treme or CR Scotseal PlusXL do not need special tools, but it does need lubrication for proper installation.



#### **Damaged O.D. beads**

If the external ridges appear damaged, most likely someone has tried to force the seal in place without proper lubrication. Burrs or dirt in the bore can also cause problems, but they're not as visible with the thick nitrile rubber protection.



#### **Worn I.D. beads**

A worn I.D. indicates the seal has been slipping on the spindle. Look for three main causes: a cocked seal, a bent seal section, or poor spindle preparation in changing from another seal to the CR Scotseal X-Treme or CR Scotseal PlusXL.



#### **Damaged I.D. beads**

Cuts or scarring in the I.D. is caused by jamming the seal into the spindle or axle tube. Misaligning the wheel dolly is usually the result of haste, however the work area should be checked to make sure the floor is smooth and free of clutter.



#### **Dented, scarred sleeve assembly**

A dimpled or dented surface indicates damage caused by a problem during installation. Lack of lubrication would be a prime suspect, but a poorly prepared hub or the use of hard-faced tools or seal driver could be the culprit.

# Failure analysis:

CR Scotseal **X-Treme** and CR Scotseal **PlusXL**

## Opening a CR Scotseal X-Treme or CR Scotseal PlusXL



Use pliers to straighten the flange on the sleeve section. Be sure to wear gloves or use a shop rag to protect your hands. The opened flange is extremely sharp.



Pull the two components apart. Then set the sleeve assembly aside (the top component shown above). Place it carefully where it is out of the way, but won't be disturbed.

## Internal inspection – sealing lip condition

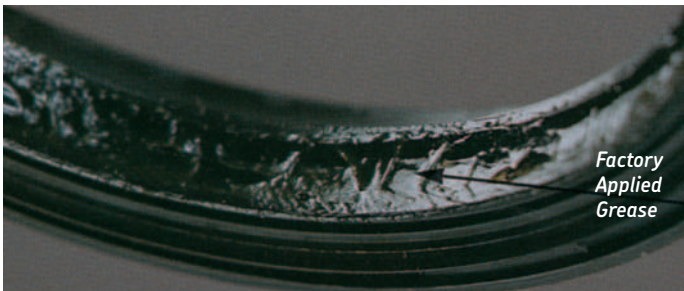

### Check for grease

Locate the primary sealing lip and radial dirt lip. If the area between them is dry, something has allowed oil to wash away the grease. The cause could be excessive end-play or a cocked seal. Or internal pressure from a blocked vent.



### Normal lip flexibility

Check the primary sealing lip and dirt lips by pressing downward on them with your thumbs, sliding them around the entire circumference. The rubber should remain soft and flexible in normal use.



### Cracked lips

If, when you check the primary and dirt lips the nitrile feels rough and dry, it has probably been subjected to excessive heat. Loss of lubrication and overtightened bearing adjustment are the prime suspects.

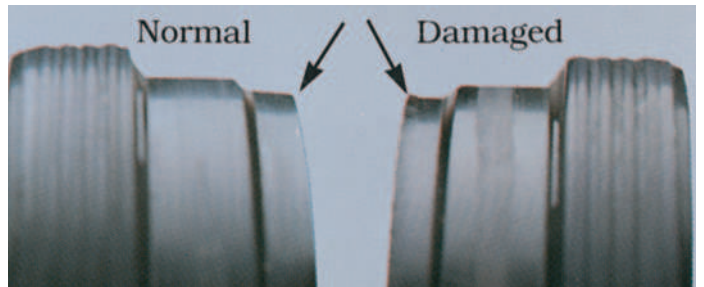

### Flattened bumper lip

Scale or rust on the spindle will prevent the wider CR Scotseal X-Treme or CR Scotseal PlusXL from sealing properly. This creates extra pressure on the bumper and axial dirt lips. The spindle must be fully cleaned and all wear rings removed before installing a CR Scotseal X-Treme or CR Scotseal PlusXL.

# Failure analysis:

CR Scotseal *X-Treme* and CR Scotseal *PlusXL*

## Internal inspection – primary and radial dirt lip wear patterns



Primary lip wear pattern

Radial dirt lip wear pattern

**Good primary lip pattern**

You should see two parallel lines. The primary lip line is slightly wider than the radial lip marking, because it's a SKF Wave Seal design.

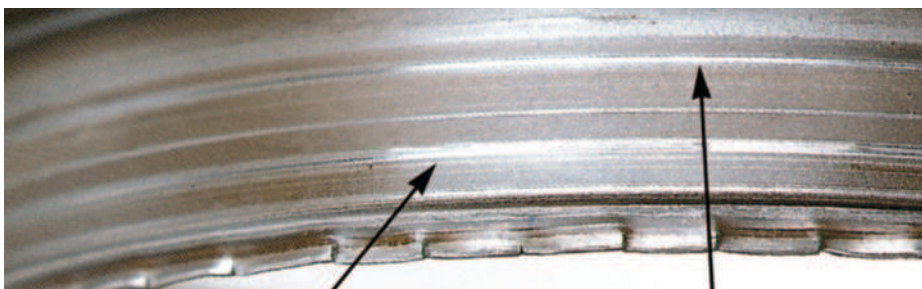

Primary lip wear pattern

Radial dirt lip wear pattern

**Wide, wide**

If both of the tracks formed by the primary and dirt lips are wide, chances are the whole wheel assembly is moving in and out at an excessive rate. End-play like this causes leaks as well as increased tire wear. The solution, of course, is proper bearing adjustment.



Primary lip wear pattern

Radial dirt lip wear pattern

**Wide, thin**

If the primary seal lip line (bottom) is extra wide, while the radial dirt lip line (top) is light, there is excessive pressure on the primary lip. For steer and trailer axles that can be a plugged vent, on drive axles the tube vent may be locked.

# Failure analysis:

CR Scotseal **X-Treme** and CR Scotseal **PlusXL**

## Internal inspection – Axial dirt lip and bumper lip wear patterns



### Good axial and bumper lip patterns

When you examine the axial face, you have two more wear patterns to learn from. About half way up on the face you should see a pencil line track from the axial lip, and at the top edge a gently scuffed pattern from the bumper lip.

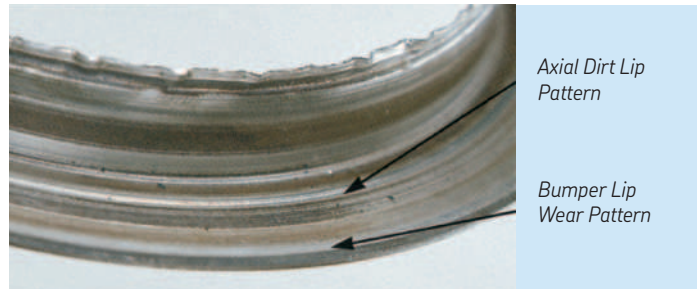

### Wide, shiny

If both lines are wide or polished clean, then you should suspect that the seal has been compressed. This will happen if the I.D. of the seal isn't lubricated before installation, if the sleeve wasn't sealed fully on the spindle, or if the bearing adjustment is too tight.

### Hard contact

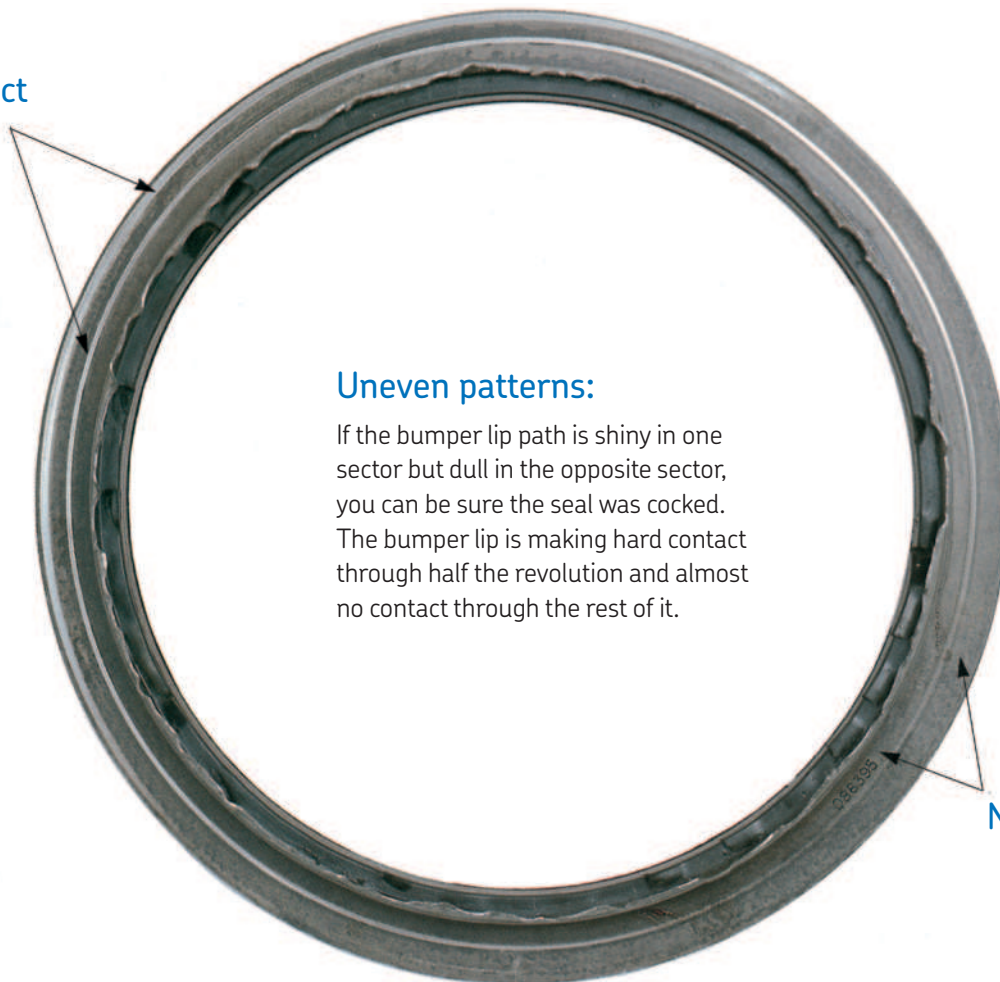

# Failure analysis:

## CR Scotseal *Classic*

### External inspection – outer diameter



#### **Normal scuffing**

The surface will show some scraped areas, that's normal. But signs of nicks, scratches metal particles, or any foreign material are warning flags that something else is amiss. Make sure the hub bore is smooth and free of burrs or nicks.



#### **O.D. radial grooves**

If the Bore Tite film has been scored all the way across the width of the seal, you should inspect the hub for burrs or damage. Before installation, the hub should be inspected and cleaned with emery cloth or a fine file.



#### **Lines in the Bore Tite**

If you see lines around the seal, several things could have happened. If the lines are etched to the metal, the seal could have spun as a result of being the wrong application or, more likely, it was installed crooked or cocked.

As you can see in this example, the grooves run from high on the left to low on the right, indicating a cocked installation. Most likely, the seal was not properly "bottomed-out" or a centering tool was not used — common causes of premature seal failure.

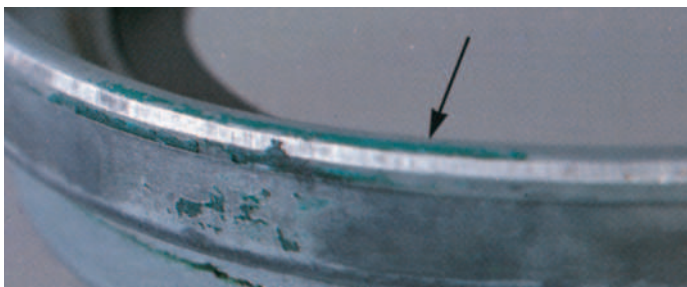

#### **Shiny leading edge**

Occasionally someone will try to improve seal installation by changing the shape of the seal. They'll round off the leading edge of the outer cup on a grinder. This distorts the outer diameter and can possibly cause the seal to disassemble.

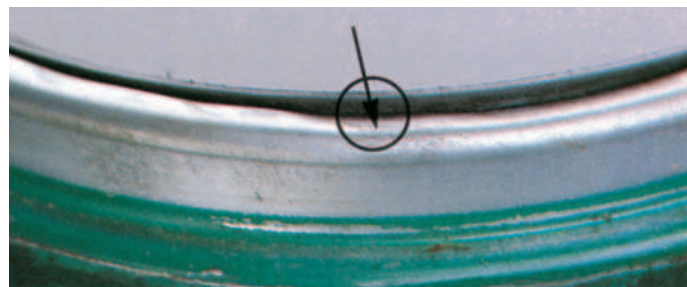

#### **Outer cup damage**

If you see dents, nicks, or a bent casing you can bet that the seal was installed without the proper tool or the tool was damaged. Gashes indicate the use of a sharp object, like a screwdriver or punch.

# Failure analysis:

## CR Scotseal *Classic*

### External inspection – inner diameter

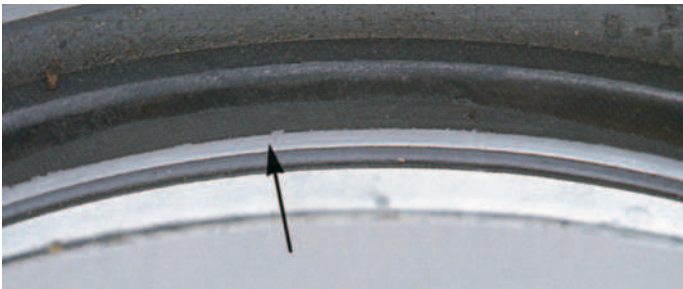

#### **I.D. wear**

If the I.D. of the packing is shiny, or has axial scratches, the seal has spun on the shaft. That can be caused by not bottoming-out the seal properly, leaving it cocked in the bore or installing the wrong part number.



#### **Installed backwards**

The only way that the packing can be worn shiny, as shown here, is by rubbing against the bearing race. The only way that can happen is by putting the seal in backwards.



#### **Severely damaged I.D.**

Scratches or dents in the I.D. are signs that the seal has struck the spindle or axle tube during installation. Rushing the installation and not lining up the wheel dolly is the usual suspect. Or a rough shop floor may be the problem.



#### **Distorted packing**

One way to damage the packing of a CR Scotseal is to try to install it over a wear ring. The wear ring will deform the inner surface and ruin the seal. Any previously installed wear ring must be removed prior to installing a CR Scotseal.



#### **Foreign matter on I.D.**

Occasionally, you will come across a seal with a shaft leak that has a mysterious, tacky substance on it. Most likely someone added a silicone sealant to "improve" the seal. Old habits die hard.

Reference the CR Scotseal installation wall poster (457626) as a convenient seal and bearing installation guide.

# Failure analysis:

## CR Scotseal *Classic*

### Internal inspection



Use pliers or end cutters and work your way all the way around the seal, straightening the outer cup flange.

Remove the inner cup. Be sure to wear gloves or use a shop rag to protect your hands, the open flange edges are sharp.

Remove the packing without disturbing the lip surfaces, as shown.

### Internal inspection – the major clues



#### **Lip grease**

Every CR Scotseal comes with grease between the primary and dirt lip. If it's not there, it's very likely oil has washed it away. Suspects are excessive end-play, a cocked seal or improper ventilation of the wheel end (dirt, corrosion or paint-plugged vent).



#### **Brittle primary seal lip**

After cleaning the entire seal, use your fingers to curl the primary seal lip back. Run your finger completely around the circumference. The oil lip should be smooth and pliable. If not, the seal has overheated; lack of lubrication or overtightened bearing adjustment could be the cause. Be sure to inspect bearings carefully.

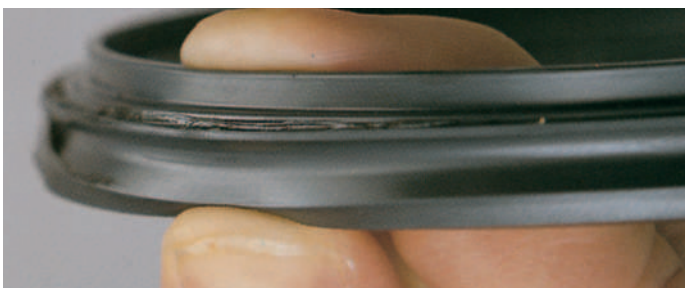

#### **Broken dirt lip**

Using the same technique, check the dirt lip. If it's dry and brittle, most likely it's been baked. It will probably split away from the seal at some point around the circumference.

Lack of lubrication may have fried the bearings as well.

# Failure analysis:

## CR Scotseal *Classic*

### Internal inspection – wear tracks

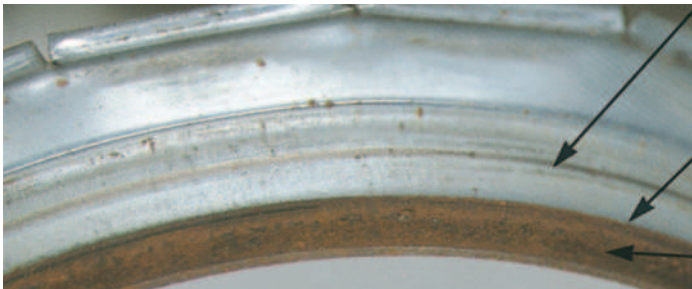

Primary Lip Wear Pattern

Dirt Lip Wear Pattern

Contamination Being Excluded

#### **Good pattern**

What you will see in a good CR Scotseal are the two parallel lines that look like they've been drawn with a sharp pencil. They're approximately the same size and equidistant from the edge all the way around the inside of the outer cup.

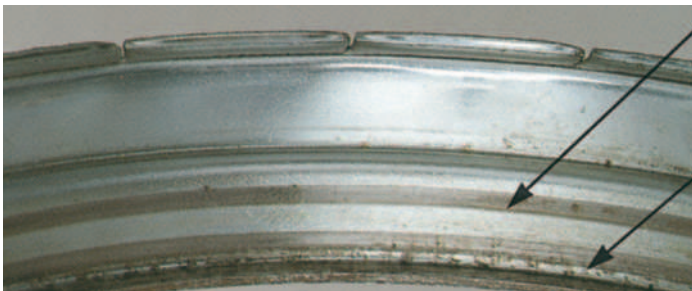

Primary Lip Wear Pattern

Dirt Lip Wear Pattern

#### **Wide, wide**

If both lines are wider than pencil lines, it means that the primary lip and dirt lip have been allowed to move in and out on the outer cup. The cause of this is excessive end-play, indicating that the bearing end-play is greater than the recommended range of .001" and .005".



#### **Metal shavings in lip area**

Before cleaning the seal, inspect the seal area for traces of metal particles. A magnet can attract metal particles. Sharp edges of metal may have cut the seal primary lip causing the seal to leak.



#### **Cocked seal—inner markings**

Holding the outer cup just below eye level and flat, like a bowl, rotate your wrist through 360°. If the seal has run cocked, the two lines will be parallel to each other, but they appear to move closer and then farther from the outer cup flange.

# Inspection:

## Bearing cup

The most commonly damaged portion of the bearing cup is the tapered raceway surface inside the cup. Make a careful inspection and look for the following:

- Evidence of corrosion
- Metallic debris
- Pitting of the surface
- Metallic flakes
- Any other signs of damage or foreign matter

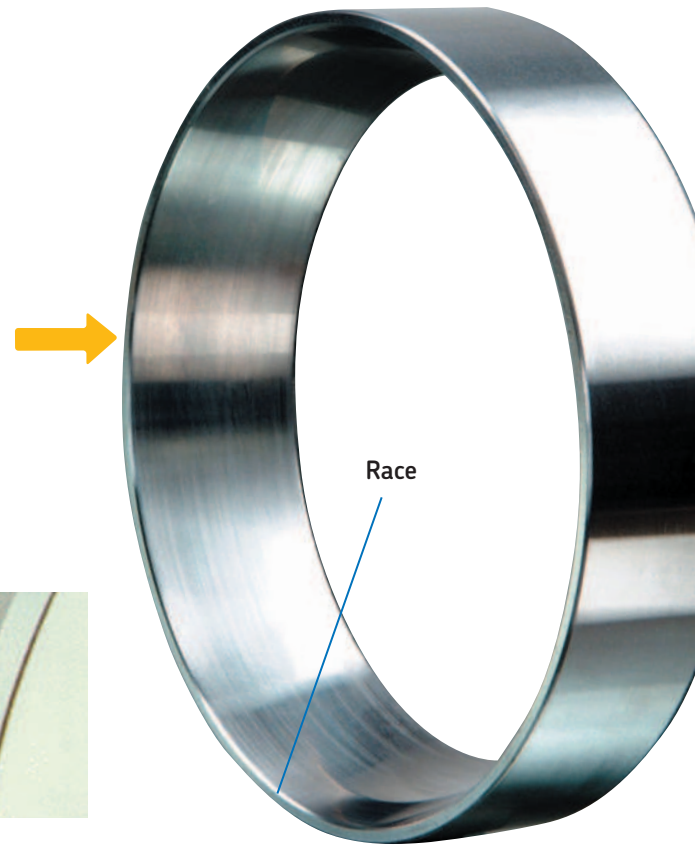

Severe sliding wear due to presence of hard abrasives.



Etching of metal generally indicates water contamination, allowing oxidation to attack the surface.



Dent across the race indicates a sharp high impact.



Cup shows considerable corrosion. This will develop in spalling.



Heavy grooving by large hard particles in the lubricant.



Dings and dents in the bearing surfaces indicates a drift was used during installation.



Typical surface appearance with repeated effects of vibration (called "false brinelling").



Surface appearance caused by electrical arcing during welding.

# Inspection:

## Bearing cone

The cone of the bearing is a composite assembly consisting of taper rollers and a metal or polymer cage. This cage contains the rollers and an inner ring which is the interface surface with the shaft or spindle.

Since there are many moving parts on the cone, you should slowly rotate the cone assembly for proper inspection of all surfaces of the components.

Make a careful inspection and look for the following:

- Corrosion
- Metallic debris
- Pitting
- Metallic flakes
- Other signs of damage or wear

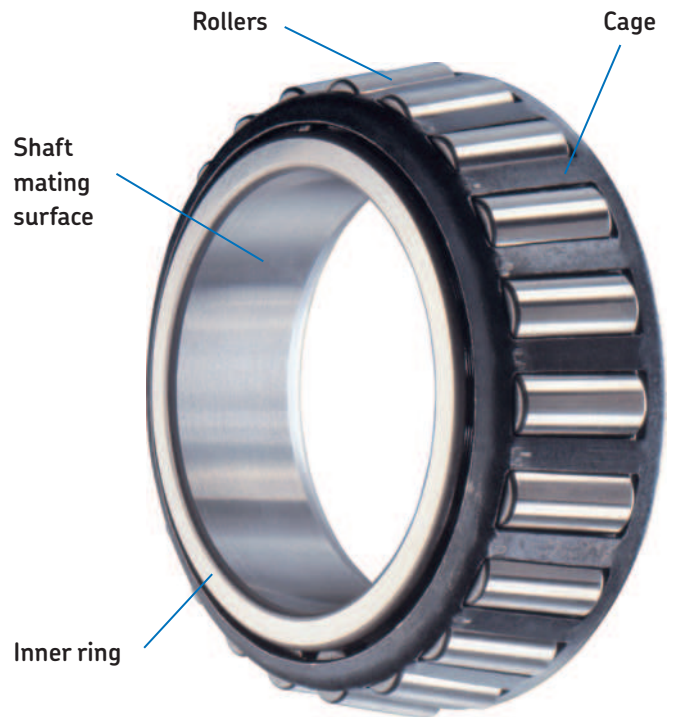

Roller end fracture due to heavy stress peaks caused by slackness of too loose bearing adjustment.



Roller end wear caused by over tightening, lubrication degradation, or lack of lubricant.

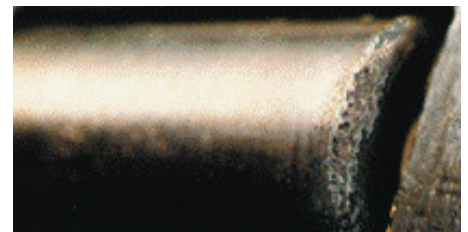

Roller end cracks indicate excessive loading or excessive misalignment.

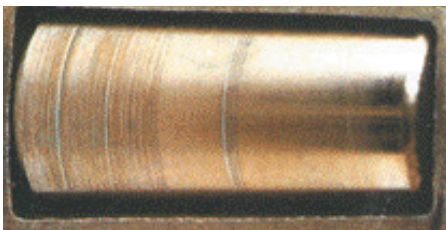

Scoring indicates contamination by dirt, grit or metallic particles.

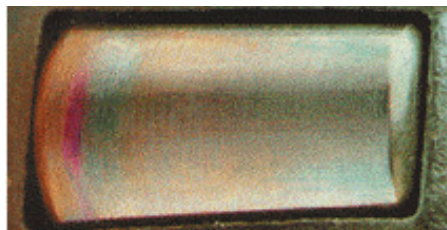

Coloration indicates an overheated bearing - from straw brown to deep purple. Causes are lack of lubricant, misadjustment or excessive loading.

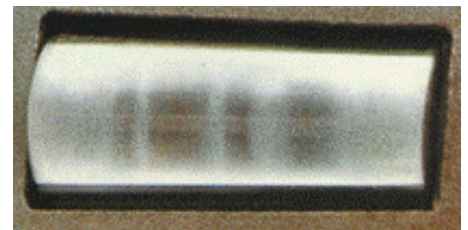

Wear marks in bands are due to foreign particles causing mild abrasive wear.

**NOTE:** Not to be confused with honing marks, which occur in the manufacturing process that produces a precision surface.

# Inspection:

## Bearing cage and inner ring

The bearing cage is made of either pressed steel or polymer and is therefore subject to various forms of damage.

These cages are deformed due to rough handling (dropping on the floor, being thrown in a box with other hard components, etc.) or poor installation with shock loads caused by hammering during removal or installation.



*Inspection of the inner ring often requires a sharp eye because the damage can be very subtle. The most common types of fatigue damage are shown below.*

*Examine the inner ring raceway by holding the bearing against a light and turning the cage slowly. Look for pitting, flaking, discoloration and corrosion.*



**Dirt**



**Misalignment**



**Insufficient lubricant**

# Failure analysis for bearings:

## Improper bearing adjustment

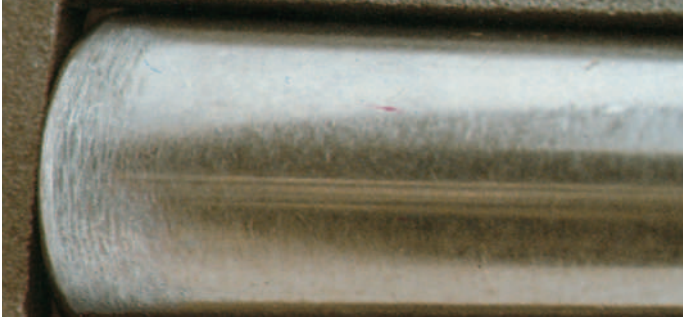

Large end of roller shows scoring, the result of excessive preload.



Large end of the roller shows spalling, the result of insufficient lubrication and/or excessive preload.

## Pitting

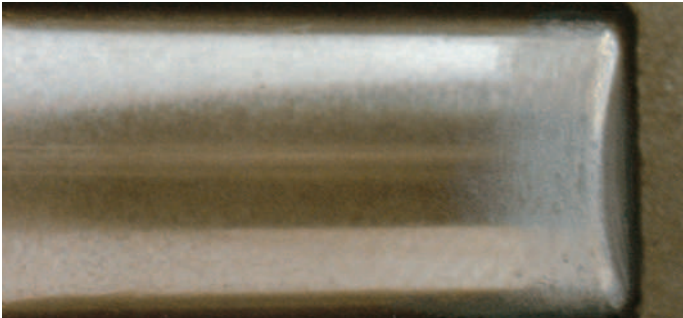

Small end of the roller shows excessive wear, the result of loose bearing adjustment.



Pitting of the race, as a result of debris in the lube causing surface deformation.

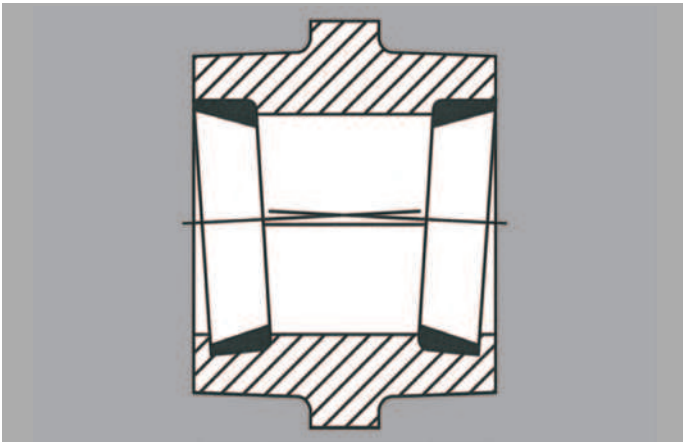

## Misalignment

Misalignment occurs when the center lines of the two bearings are not parallel to each other. The causes can be an improperly seated bearing, where dirt or burrs prevent a flush mount; an outer cup installed without the proper tool; a warped shaft; or nut faces that are out of line.

# Failure analysis for bearings:

## Misalignment



*Uneven wear on the roller, the result of improper installation.*

## Contamination



*Circular wear in the race, the result of hard particle contamination in the lube.*



*Vertical etching on the race, the result of moisture contamination within the lube.*

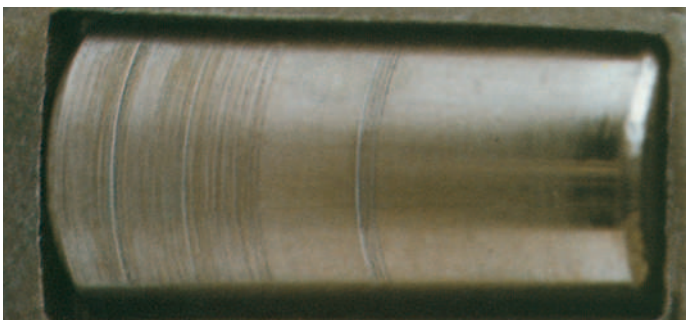

*Circular wear on the roller, the result of hard particle contamination in the lube.*

# Failure analysis for bearings:

## Misalignment



*Peeling, the tearing away of metal from the race, the result of the breakdown of lubrication.*



*Discoloration indicates high levels of heat, the result of improper lubrication or improper bearing adjustment.*

## Installation damage



*Deformation of the cage, the result of improper installation or mishandling prior to installation.*



*Cage damage, the result of abuse prior to or during installation.*



*Cracked cone, the result of misapplication or cocking the cone at installation.*



*Damage to the cup front face, the result of installation damage through use of a hardened driver.*

# Failure analysis for bearings:

## Brinelling



*Brinelling, the result of severe impact to the bearing, causing one or more of the roller bodies to deform the surface of the race.*

## Other damage



*Fretting corrosion of the outer surface is often the result of a worn hub or spindle.*



*Light pitting can be caused by electrical arcing. The probable cause is electrical welding grounded through the shaft.*



*Spalling, the wearing away of metal from the bearing surface, the result of contamination, brinelling, improper installation, improper lubrication, or the normal end of bearing life.*

# Failure analysis for hubcaps:

## Inspection of lubricant and hubcap

The hubcap is constantly exposed to the environment. That means hot, cold, wet, dry and salty. But some of its roughest treatment can come from inside. A lack of lube or an over-tight bearing adjustment can cook the hubcap and permanently damage it. Here are a few of the clues to indicate why a hubcap has failed.



### **Distorted bolt hole**

Bolt hole, or flange distortion, may be the result of excessive bolt torque during installation. The use of an impact wrench may damage the flange at the bolt hole area during assembly.



### **Milky window**

The view window in the hubcap will become nearly opaque white when subject to heat. The heat comes from inside and spells trouble. You'll want to pull the wheel and check the bearing adjustment, check for low lube or a change to an incompatible lubricant.

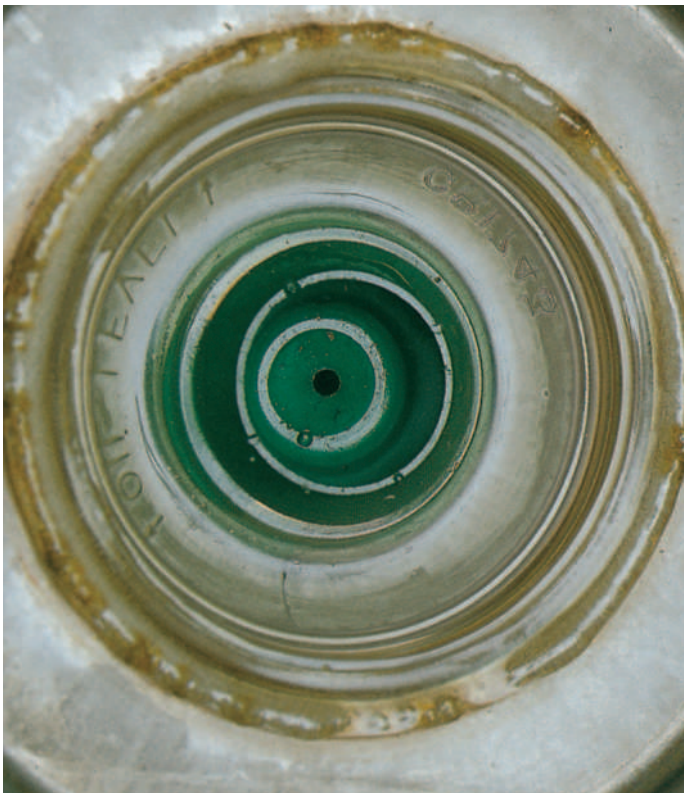

### **Melted window**

With the hubcap removed, inspect the edges of the view window for damage or discoloration. If the edge has a rippled look, chances are it has started to melt from excessive heat. Heat build-up could be from running low on lube, excessive pre-load on bearing or a recent switch to an incompatible lubricant.

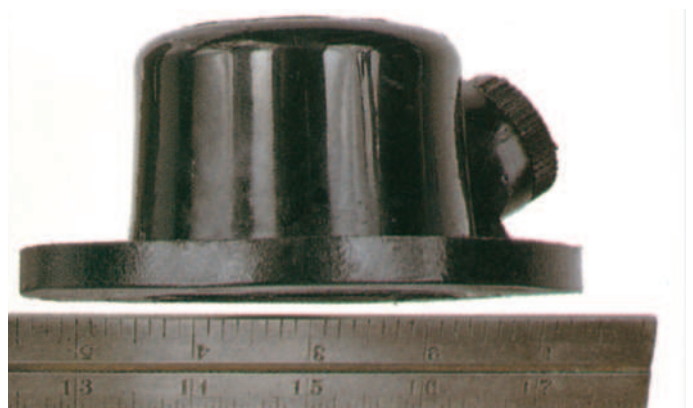

### **Warped Flange**

Place hubcap on a flat surface. When flange is distorted it will not hold contact all the way around. Proper torque specifications may not have been followed.

## CR Scotseal family

National to CR			National 5-Star to CR			Stemco GritGuard to CR			Stemco Voyager to CR		
National	CR Scotseal Classic	CR Scotseal PlusXL	National 5-Star	CR Scotseal Classic	CR Scotseal PlusXL	Stemco GritGuard	CR Scotseal Classic	CR Scotseal PlusXL	Stemco Voyager	CR Scotseal Classic	CR Scotseal PlusXL
370001A	35066	35058 ♦	380001A	35066	35058 ♦	372-7048	31323	—	373-0113	40136	40129 ♦
370003A	47697	47691 ♦	380003A	47697	47691 ♦	372-7095	43752	43754	373-0123	42623	42627 ♦
370005A/	48000	48002	380022A	45099	45093	372-7097	46305	46300 ♦			or 42500*
370173A	(GMC) 47690	—	380023A	38780	38776 ♦			or 42626*	373-0143	46305	46300 ♦
370006A	47699	—	380025A	46305	46300 ♦	372-7098	40136	40129 ♦			or 42626*
370007A	48794	—			or 42626*	372-7099	42623	42627 ♦	373-0144	43752	43754
370009A	39420	—	380031A	42672	42673 ♦			or 42500*	383-0101	40086	40091
370011A	36358	—	380036A	40136	40129 ♦	382-8001	40086	40091	383-0136	35066	35058 ♦
370012A	36285	—	380048A	43764	43761 ♦	382-8028	48794	—	383-0139	39988	39979
370015A	40040	—	380065A	42623	42627 ♦	382-8034	36285	—	383-0153	44922	44916
370019A	43860	—			or 42500*	382-8036	35066	35058 ♦	383-0156	45103	45095
370021A	45160	45157	380131A	45103	45095	382-8039	39988	39979	383-0164	43764	43761 ♦
370022A	45099	45093	386025A	46305	46300 ♦		w/456301	w/456301	383-0166	28758	28759
370023A	38780	38776 ♦			or 42626*	382-8044	28832	—	383-0171	36358	—
370024A	38750	—	386590A	42623	42627 ♦	382-8053	44922	44916	383-0175	—	23590
370025A	46305	46300 ♦			or 42500*	382-8056	45103	45095	383-0176	—	29400
		or 42626*				382-8063	34975	34971	393-0103	45099	45093
370031A	42672	42673 ♦				382-8064	43764	43761 ♦	393-0104	42672	42673 ♦
370033A/	39988	39979				382-8066	28758	28759	393-0112	38780	38776 ♦
AR-12	w/456301	w/456301				382-8071	36358	—	393-0115	38750	—
370036A	40136	40129 ♦				392-9033	44964	—	393-0134	48690	—
370037A	43752	43754					w/OEM Ring	—	393-0173	47697	47691 ♦
370046A	31323	—				392-9035	34387	34384			
370047A	34387	34384				392-9038	31323	—			
370048A	43764	43761 ♦				392-9054	48690	—			
370054A	28832	—				392-9081	48000	48002			
370065A	42623	42627 ♦				392-9087	47699	—			
		or 42500*				392-9088	45160	45157			
370066A	40086	40091				392-9089	52658	—			
370069A	52658	—				392-9089	47697	47691 ♦			
370124A	44922	44916				392-9090	42672	42673 ♦			
370131A	45103	45095				392-9094	45099	45093			
370132A	34975	34971				392-9096	43860	—			
370150A	28758	28759				392-9097	47690	—			
370165A	38747	—				392-9099	38780	38776 ♦			
370173A	48000	48002					(GMC) 38750	—			
370178A	44964	—					(IHC) 38747	—			
370181A	47690	—				382-9131	47697	47691 ♦			
370182A	43764	43761 ♦									
370195A	48690	—									
370199A	—	23590									
370211A	—	29400									
370338A	43752	43754									
370349A	40136	40129 ♦									
376590A	42623	42627									
		or 42500*									

Stemco Guardian HP to CR		
Stemco Guardian	CR Scotseal Classic	CR Scotseal PlusXL
307-0713	40136	40129 ♦
307-0723	42623	42627 ♦
		or 42500*
307-0743	46305	46300 ♦
		or 42626*
307-0744	43752	43754
308-0836	35066	35058 ♦
308-0853	44922	44916
308-0856	45103	45095
308-0864	43764	43761 ♦
308-0866	28758	28759
309-0903	45099	45093
309-0904	42672	42673 ♦
309-0912	38780	38776 ♦
309-0915	38750	—
309-0935	34387	34384
309-0960	48000	48002
309-0964	45160	45157
309-0965	43860	—
309-0970	47699	—
309-0973	47697	47691 ♦

Stemco Discover to CR		
Stemco Discover	CR Scotseal Classic	CR Scotseal PlusXL
373-0213	40136	40129 ♦
373-0223	42623	42627 ♦
		or 42500*
373-0243	46305	46300 ♦
		or 42626*
383-0236	35066	35058 ♦
383-0239	39988	39979
383-0264	43764	43761 ♦
393-0203	45099	45093
393-0204	42672	42673 ♦
393-0273	47697	47691 ♦
393-0212	38780	38776 ♦

\* Tool installed CR Scotseal Hybrid version (spindle mount)

♦ For CR Scotseal X-Treme, add suffix XT to part number

# Hubcaps

SKF TF/Zytel			Stemco				National	Dual Dynamics		SKF
Oil	Grease	Application	Oil	Sentinel Oil	Sentinel Grease	Oil	Oil	Grease	Steel	
1282 <sup>1</sup>	1284 <sup>1</sup>	Pro-Par Trailer	340-4975				HU-075A	276-P	275-G	
1600		Trailer/Hubo	347-4009				DG-6FL			
1608 <sup>2</sup>		Steer	340-4065	343-4065			HU-065A			
1612 <sup>2</sup>	1326	Steer	340-4024	343-4024	356-4024		HU-024A	302-P	301-G	1711
1613 <sup>2</sup>		Steer	340-4249	343-4249			HU-110A			1703
1623		Trailer	340-4066	343-4066			HU-066A			1723
1627		Trailer	340-4002	343-4002			HU-019A			1727
1627		Steer	340-4019	343-4019			HU-024A			
1630 <sup>2</sup>		Trailer	340-4014	343-4014					202-G	
1642		Trailer	340-4013	343-4013		348-4013 349-4013	HU-013A	282-P		1742
1643	1343	Trailer	340-4009	343-4009		348-4009 349-4009	HU-009A	203-P	283-G	1743
1643	1343	Trailer	340-4249	343-4249			HU-110A	303-P	304-G	
1644 <sup>2</sup>	1343	Trailer/Steer	340-4009	343-4009		348-4009 349-4009	HU-009A			1743
	1343W	Trailer				342-4009				
1665		Trailer	340-4042	343-4042			HU-042A			1765
1669 <sup>2</sup>		Steer	340-4025	343-4025			HU-036A			
1670 <sup>2</sup>		Steer	340-4034	343-4034			HU-034A			1770
1670 <sup>2</sup>		Steer		343-4072			HU-034A			1770
1681		Trailer	340-4186	343-4186			HU-028A			
1691 <sup>2</sup>		Steer	340-4098	343-4098			HU-009A			1790
1696	1399	Trailer	340-4195	343-4195		348-4195 349-4195		257-P	255-G	1796
	1399W	Trailer				342-4195				
1698		Trailer	340-4195	343-4195						1798
1698		Trailer	340-4080	343-4080						
1943 <sup>3</sup>	1443	Trailer	340-4370	343-4370			HU-007A	207-P	401-G	
1945 <sup>4</sup>	1443	Trailer	340-4370	343-4370			HU-007A	207-P	401-G	
1995 <sup>4</sup>	1499	Trailer	340-4372	343-4372				260-P	456-G	
1996 <sup>3</sup>	1499	Trailer	340-4372	343-4372				260-P	456-G	

1-Lexan design 2-Black design 3-Designed for PSI system, Gray 4-Designed for PSI system, Black

## Splashguard center plugs



(Available in green and black 4 packs)	Standard center plug	Splashguard center plug
Green	450434-4	450439-4
Black	453807-4	450438-4
Display (6 sets each)		454210
Display (12 sets green)		454215
Display (12 sets black)		454216

## Tapered bearing sets

SKF Standard set no.	SKF Half stand brg. sets	General bearing application	SKF Components		Competitive interchanges	
			Cone no.	Cup no.	BCA Set no.	Timken Set no.
<b>SET401</b>	<b>SET430</b>	R Drive Axle (outer)	BR580	BR572	HD206	SET401
<b>SET402</b>	—	R Drive Axle (outer)-Mack	BR582	BR572	HD211	SET402
<b>SET403</b>	<b>SET429</b>	R Drive Axle (inner)	594-AVP	592-AVP	HD203	SET403
<b>SET404</b>	—	R Drive Axle (inner)-Mack	598-AVP	592-AVP	HD204	SET404
<b>SET405</b>	—	Trailer Axle (inner) & Rear Drive Axle/Trailer Axle (outer)	BR663	BR653	HD207	SET405
<b>SET406</b>	<b>SET428</b>	FF Steer Axle (outer)	BR3782	BR3720	HD205	SET406
<b>SET407</b>	—	Rear Axle (inner) & Front Steer Axle (outer)	BR28682	BR28622	HD213	SET407
<b>SET408</b>	—	L Drive Axle (outer)	BR39590	BR39520	HD210	SET408
<b>SET409</b>	—	Front Steer Axle (outer)-Mack	BR45280	BR45220	HD219	SET409
<b>SET410</b>	—	Front Steer Axle (inner)	BR45284	BR45220	N/A	SET410
<b>SET411</b>	—	L Drive Axle (inner)	BR47686	BR47620	HD209	SET411
<b>SET412</b>	—	FF Steer Axle (inner) & N Trailer Axle (outer)	HM212047 VP	HM212011 VP	HD202	SET412
<b>SET413</b>	<b>SET427</b>	FF Steer Axle (inner) & N Trailer Axle (outer)	HM212049 VP	HM212011 VP	HD200	SET413
<b>SET414</b>	<b>SET431</b>	N Trailer Axle (inner)	HM218248 VP	HM218210 VP	HD201	SET414
<b>SET415</b>	<b>SET432</b>	P Trailer Axle (inner & outer)	HM518445 VP	HM518410 VP	HD208	SET415
<b>SET416</b>	—	Trailer Axle	BR45291	BR45220	N/A	SET416
<b>SET417</b>	—	Trailer Axle	BR47890	BR47820	N/A	SET417
<b>SET418</b>	—	Front Steer Axle (inner)	H715334 VP	H715311 VP	N/A	SET418
<b>SET419</b>	—	Front Steer Axle (inner)	H715343 VP	H715311 VP	N/A	SET419
<b>SET420</b>	—	Front Steer Axle (inner)	H715345 VP	H715311 VP	N/A	SET420
<b>SET421</b>	—	Rear Axle (inner)-Mack	HM516449-AVP	HM516410 VP	HD214	SET421
<b>SET422</b>	—	Rear Axle (inner)-Mack	HM516449-CVP	HM516410 VP	HD212	SET422
<b>SET423</b>	—	FL Steer Axle (inner)	6461-AVP	BR6420	HD218	SET423
<b>SET424</b>	—	FL Steer Axle (outer)	555-SVP	552-AVP	HD217	SET424
<b>SET425</b>	—	Front Steer Axle/Trailer Axle (inner) & Rear Axle (outer)-Mack	BR567	BR563	HD216	SET425
<b>SET426</b>	—	Rear Axle (outer)-Mack	BR47679	BR47620	HD215	SET426
<b>SET433</b>	—	HD Tapered Set	BR594	592-A	N/A	N/A
<b>SET439</b>	—	FF Steer Axle (inner)-Volvo	HM212049-XVP	HM212011 VP	N/A	SET439
<b>SET499</b>	—	HD Tapered Set	BR687	BR672	N/A	N/A

## Half stand bearings

SKF set no.	ConMet set no.	SKF cone	SKF cup	Timken LMS set no.	Timken cone	Timken cup	Position
Pre-adjusted half stand interchanges							
<b>SET427</b>	107500	RBT10433	LBT10433	SET427	NP899357	NP026773	Inner FF front
<b>SET427</b>	107500	RBT10433	LBT10433	SET427	NP899357	NP026773	Outer TN trailer
<b>SET428</b>	107501	RBT10429	LBT10429	SET428	NP874005	NP435398	Outer FF front
<b>SET429</b>	107502	RBT10434	LBT10434	SET429	NP034946	NP363298	Inner R drive
<b>SET430</b>	107503	RBT10431	LBT10431	SET430	NP840302	NP053874	Outer R drive
<b>SET431</b>	107504	RBT10430	LBT10430	SET431	NP965350	NP503727	Inner TN trailer
<b>SET432</b>	107506	RBT10426	LBT10426	SET432	NP174964	NP593561	Inner/Outer TP trailer
LMS half stand interchanges							
<b>SET427</b>	107500	RBT1-0433	LBT1-0433	SET433	NP431952	NP378092	Inner FF front
<b>SET427</b>	107500	RBT1-0433	LBT1-0433	SET433	NP431952	NP378092	Outer TN trailer
<b>SET428</b>	107501	RBT1-0429	LBT1-0429	SET434	NP555065	NP720703	Outer FF front
<b>SET429</b>	107502	RBT1-0434	LBT1-0434	SET435	NP588900	NP107783	Inner R drive
<b>SET430</b>	107503	RBT1-0431	LBT1-0431	SET436	NP577914	NP975161	Outer R drive
<b>SET431</b>	107504	RBT1-0430	LBT1-0430	SET437	NP022333	NP250023	Inner TN trailer
<b>SET432</b>	107506	RBT1-0426	LBT1-0426	SET438	NP417549	NP156827	Inner/Outer TP trailer

## Rebuild kit for pre-adjusted hubs

Rebuild kit part number	Position	Scotseal Plus XL	Inner half stand bearing	Outer half stand bearing	Hubcap	Spacer
<b>FFSK1</b>	FF steer axle	35058	SET427	SET428	1612	103592
<b>RDSK1</b>	R drive axle long and short haul	47691	SET429	SET430	N/A	103593
<b>TNSK1</b>	TN trailer axle, oil bath	46300	SET431	SET427	1643	104144
<b>TNSK2</b>	TN trailer axle, grease	46300	SET431	SET427	1343	104144
<b>TPSK1</b>	TP trailer axle, oil bath	42627	SET432	SET432	1696	104412
<b>TPSK2</b>	TP trailer axle, grease	42627	SET432	SET432	1399	104412

## Unitized pinion seals

SKF unitized	Axles	Position	Arvin Meritor No.	National No.	Stemco No.	SKF DL	SKF Grease	Bore	Yoke shaft
<b>32500</b>	14X/16X/18X/38X	F-R UI (FUJ) <sup>1</sup>	A1205R2592/ A11205X2728	100494	429-0007	32385	32397	4.249	3.250
<b>30008</b>	14X/16X	F-R UO (FUO) <sup>2</sup>	A1205P2590/ A11205Y2729	100495	429-0005	30007	29867	3.751	3.000
<b>30009</b>	14X	R-R UI (RUI) <sup>3</sup>	A1205N2588/ A11205Z2730	100263	429-0010	30153	30145	4.936	3.000
<b>32503</b>	16X/18X	R-R UI (RUI) <sup>3</sup>	A1205Q2591/ A11205A2731	100557	429-0011	33254		5.501	3.250

1 - F-R UI - Forward-Rear Unit Input (FUJ)

2 - F-R UO - Forward-Rear Unit Output (FUO)

3 - R-R UI - Rear-Rear Unit Input (RUI)

## Two-piece wheel nut

Part number	Size	Outside diameter	Number of pieces in container	Metform Securex part number
<b>MV33333-10</b>	M22 × 1.5 (high profile)	33 mm hex	10 ct. box	39702
<b>MV33333G-100</b>	M22 × 1.5 (high profile)	33 mm hex	100 ct. box	39702
<b>MV33333B-300</b>	M22 × 1.5 (high profile)	33 mm hex	300 ct. bucket	39702
<b>MV22273-10</b>	M22 × 1.5 (low profile)	33 mm hex	10 ct. box	39874
<b>MV22273G-130</b>	M22 × 1.5 (low profile)	33 mm hex	130 ct. box	39874
<b>MV88838-10</b>	M22 × 1.5	38 mm hex	10 ct. box	39514
<b>MV88838G-80</b>	M22 × 1.5	38 mm hex	80 ct. box	39514

## Spindle nut

Assembly part number	Add suffix for bulk qty.	Application	Thread size	Outer tapered bearing	Hex socket (6 point)	Hardened washer	Lock screws	Stemco interchange
			inches		inches			
<b>SN150CWFF</b>	G-45	Steer Axle-Meritor/Navistar	1.50–12	SET406	2.00	W150CWBW	8V37-8	448-4836
<b>SN150FWFE</b>	G-45	Steer Axle-Meritor/Eaton/Ford	1.50–18	SET406	2.00	W150CWBW	8V37-8	448-4837
<b>SN262GWDA</b>	G-25	Drive Axle-Meritor/Eaton/Ford/Navistar	2.625–12	BR3984/BR3920, SET408	3.00	W262KWBW	25R37-8	449-4974
<b>SN262KWTDN</b>	G-25	Trailer Axle-Meritor/Dana/Eaton	2.625–16	SET413	3.00	W262KWBW	25R37-8	447-4743
<b>SN325GWDT</b>	G-20	Drive Axle-Meritor/Dana/Eaton/Mack/Navistar <sup>3</sup>	3.25–12	SET401	3.75	W325GWBW	25R37-8	449-4973
<b>SN348GWSP <sup>1</sup></b>	N/A	Trailer Axle-Meritor/Dana/Freuhaf/Hendrickson	3.48–12	SET415	4.125	W345GWBW	25R37-8	447-4723
<b>SN348GWTP <sup>2</sup></b>	G-20	Trailer Axle-Meritor/Dana/Freuhaf/Hendrickson	3.48–12	SET415	4.125	W350GWBW	25R37-8	447-4723
<b>SN350GWTA</b>	G-20	Trailer Axle-Eaton	3.50–12	SET415	4.125	W350GWBW	25R37-8	447-4724

Note: Individual hardened washers and lock screws are included in the assembly or can be ordered individually

Note: Each assembly part number includes mating washer and lock screws

**1** - Can be used with all hubcap brands    **2** - Designed for SKF hubcaps

**3** - Also fits trailer axles for Meritor TR and Dana EST230-P & P22TQ (axles before 1/1/2006 & uses outer bearing SET415)

## Sleeve nut

Part number	Size	Outside diameter	Number of pieces in container
<b>SLN22006-10</b>	M22-1.5 × 6 mm sleeve nut	33 mm hex	10 ct. box
<b>SLN22006G-100</b>	M22-1.5 × 6 mm sleeve nut	33 mm hex	100 ct. box
<b>SLN22195-10</b>	M22-1.5 × 19.5 mm sleeve nut	33 mm hex	10 ct. box
<b>SLN22195G-70</b>	M22-1.5 × 19.5 mm sleeve nut	33 mm hex	70 ct. box
<b>SLN22280-10</b>	M22-1.5 × 28 mm sleeve nut	33 mm hex	10 ct. box
<b>SLN22280G-70</b>	M22-1.5 × 28 mm sleeve nut	33 mm hex	70 ct. box
<b>SLN22395-10</b>	M22-1.5 × 39.5 mm sleeve nut	33 mm hex	10 ct. box
<b>SLN22395G-70</b>	M22-1.5 × 39.5 mm sleeve nut	33 mm hex	70 ct. box

# CR Scotseal Classic installation tool

## Drive plates & seal matchups

Table 1

Drive plates appear in bold with matching seal numbers.

<b>427</b>	<b>445</b>	<b>457</b>
34387	39380	40040
36285	39420	40136
36358	39425	40139
36365	42550	
	42672	
<b>428</b>	42800	<b>461</b>
31175		45152
31244		45160
31281	<b>446</b>	45162
31323	43860	
32470	43865	<b>462</b>
	43875	38747
	46390	38750
<b>435</b>	47483	38780
47690	48690	
47693	48794	<b>463</b>
47697	48796	27438
47698	48884	28758
48000	50124	28820
		28832
<b>436</b>	<b>448</b>	<b>465</b>
34975	38709	43752
35000	39988	43764
35060		43800
35066	<b>449</b>	
35072	47699	
35075		<b>473</b>
35103	<b>451</b>	39380
	46305	(w/disc brks.)
<b>441</b>	46308	
40086		<b>474</b>
	<b>452</b>	52658
	42623	
	42624	<b>484</b>
	42631	44922
		44964
		45010
		45099
		45103

## Matchup of bearing cones & centering plugs

Table 2

Precisely matched centering plugs are engineered to fit within the inside diameter of the inner bearing cone and allow accurate centering of the CR Scotseal in the bore of the hub, as well as preventing cocking of the seal.

Bearing cone no.	Centering plug no.	Bearing cone no.	Centering plug no.	Bearing cone no.	Centering plug no.
<b>495-AXVP</b>	708	<b>681-AVP</b>	714	<b>BR33895</b>	701
<b>BR497</b>	711	<b>BR683</b>	715	<b>BR39580</b>	702
<b>BR539</b>	701	<b>BR687</b>	718	<b>BR39581</b>	702
<b>555-SVP</b>	702	<b>BR749</b>	719	<b>BR39585</b>	704
<b>557-A</b>	703	<b>749-AVP</b>	710	<b>BR42688</b>	708
<b>BR559</b>	704	<b>756-A</b>	709	<b>BR45284</b>	700
<b>BR560</b>	706	<b>BR759</b>	712	<b>BR45285</b>	700
<b>BR567</b>	707	<b>BR760</b>	717	<b>BR47678</b>	708
<b>BR575</b>	708	<b>BR776</b>	715	<b>BR47686</b>	710
<b>BR580</b>	710	<b>BR780</b>	718	<b>BR47687</b>	710
<b>BR582</b>	710	<b>BR3778</b>	730	<b>BR52400</b>	718
<b>BR593</b>	712	<b>BR3982</b>	704	<b>BR52401</b>	718
<b>BR594</b>	715	<b>BR3984</b>	706	<b>JH217249</b>	719
<b>594-AVP</b>	715	<b>BR4595</b>	701	<b>JM205149-A</b>	722
<b>BR595</b>	710	<b>BR5760</b>	708	<b>JM207049-AVP</b>	723
<b>BR596</b>	711	<b>BR6379</b>	705	<b>JM511946 VP</b>	724
<b>BR598</b>	714	<b>BR6386</b>	706	<b>JM716649</b>	719
<b>598-AVP</b>	714	<b>BR6389</b>	706	<b>JM718149 VP</b>	713
<b>BR639</b>	704	<b>BR6461</b>	708	<b>JM719149</b>	733
<b>BR641</b>	706	<b>6461-AVP</b>	708	<b>HM212044 VP</b>	703
<b>BR663</b>	710	<b>BR6580</b>	712	<b>HM212046</b>	704
<b>663-A</b>	710	<b>BR28995</b>	703	<b>HM212047 VP</b>	704
<b>BR665</b>	711	<b>BR33281</b>	716	<b>HM212049-XVP</b>	706
<b>665-AVP</b>	711	<b>BR33287</b>	707	<b>HM212049 VP</b>	706
				<b>HM218248 VP</b>	713
				<b>HM518445 VP</b>	712
				<b>H715345 VP</b>	716



CR Scotseals X-Treme & PlusXL



CR Scotseals Hybrid & Classic



Hubcaps



Spindle nuts



Sleeve nuts, wheel nuts and lug locks



Krown Products



Tapered bearing sets



Rebuild kit for pre-adjusted hubs



Brakemaster Air dryers



Drivetrain kits



U-joints

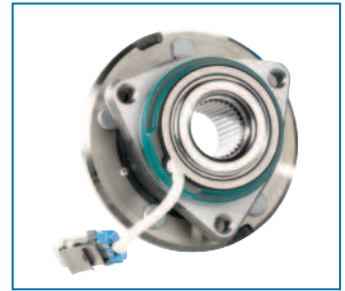

Automotive wheel hub units

SKF offers a complete line of heavy duty aftermarket products designed to keep your fleet moving and your drivers safe. Turn to SKF for safe and reliable wheel end solutions by accessing product information and technical tips through one of these outlets.

## vsm.skf.com

Download literature, access technical tips and view product information

## Mobile parts look up

Access our mobile parts look up website for all the latest part numbers at [skfpartsinfo.com](http://skfpartsinfo.com)



## SKF Parts Info Apps

Download SKF apps for access to product information, cross reference, instruction sheets, application data and brochures.



## Youtube

View detailed technical and product videos at [skfpartsinfo.tv](http://skfpartsinfo.tv)



## Twitter

Follow us on Twitter [@skfpartsinfo](https://twitter.com/skfpartsinfo) to stay on top of all the latest technical and product information.



[skf.com](http://skf.com) | [vsm.skf.com](http://vsm.skf.com) | 1-800-882-0008

© SKF, BeyondZero, TFO, TF, Scotseal, Wavesal, Bore Tite are registered trademarks of the SKF Group.

© SKF Group 2017

The contents of this publication are the copyright of the publisher and may not be reproduced (even extracts) unless prior written permission is granted. Every care has been taken to ensure the accuracy of the information contained in this publication but no liability can be accepted for any loss or damage whether direct, indirect or consequential arising out of the use of the information contained herein.

PUB 457975 · rev. December 2017

Certain image(s) used under license from Shutterstock.com